



Low voltage products

# Low voltage current transformers type: IMW, IMP, IMS, ISW, INSOA, IMR

# Low voltage current transformers

## type: IMW, IMP, IMS, ISW, INSOA, IMR

### INDEX

#### General information

Application .....	3
Operating conditions .....	3
Design .....	3
Mounting .....	3
Packing, transport, storage .....	4
Spare parts .....	4
Compliance with standards .....	4
Warranty .....	4
Handling used products .....	4
Submitting an order .....	4
Example of an order .....	4
Transformer selection .....	5

#### Technical data, dimensional drawings

Transformers type IMW with primary winding .....	6
Transformers type IMS on busbar	
IMSa .....	8
IMSb .....	10
IMSc .....	12
IMSd .....	14
Transformers type IMP on cable	
IMPa .....	16
IMPb .....	18
Transformers type ISW on busbar or cable	
ISWb .....	20
ISWb2 .....	22
ISWc .....	24
ISWd1 .....	26
ISWd2 .....	28
ISWe .....	30
ISWf .....	32
ISWg .....	34
ISWh1 .....	36
ISWh2 .....	38
Transformers type IMR to switchgear	
IMR0 .....	40
IMR1a .....	42
IMR1b .....	44
IMR2 .....	46
Special transformers INSOA .....	48

#### Accessories

Voltage terminal .....	50
Support for mounting transformer	
on a TS35 mounting busbar .....	50
Busbar mounting assembly .....	50
Standard bolt with holder for a 30 mm or 60 mm busbar .....	50
Copper sleeve .....	50
Busbars .....	51
Transformer selection table .....	52
Primary current range .....	56
Certificates .....	56

# General information

## APPLICATION

Low voltage current transformers are intended for supplying measuring instruments and protection circuits of electrical power devices with a maximum operating voltage of 0.72 kV and frequency of 50 Hz (or 60 Hz after prior arrangement with the manufacturer). Transformers of power utility installations. The transformers are manufactured for secondary currents 1A and 5A. The range of primary currents depends on the transformer and can range from 1 A up to 6,000 A.

## OPERATING CONDITIONS

The transformers are designed for operation in indoor equipment in climatic conditions: temperate (N3) or tropical (T3). The long-term thermal rated current and limits of deviations of these transformers correspond to an extended current range of 120% of  $I_{pn}$  within the ambient temperature range from 248 K (-25°C) to 328 K (+55°C). It is possible to produce some transformers with a 150% or 200% current range by special arrangement with the manufacturer.

## DESIGN

The low voltage current transformers are single-phase, low power transformers, operating in quasi short-circuit conditions and transforming the current flowing through the primary circuit to the current in the secondary circuit with a level of accuracy specified in relevant standards. Their insulation class is E or A. The windings of the current transformers are enclosed in the housings made of heat and fire resistant material.

The current transformers are produced for different types of primary circuits: busbar or cable according to the transformer selection table (page 52). The range of primary currents is from 1 A up to 6000 A. Transformer types: IMW, IMP, IMS, IMR2 and ISW (with the exception of ISWc) have offer the option of a sealing cover for

secondary terminals. Transformers are permanently marked with the rated ratio on both sides of the casing. They have slides allowing assembly to the base and screws or holder for mounting on the current circuit. Equipment details are stated in the transformer selection table (page 52).

## MOUNTING

Low voltage current transformers can be mounted on:

- current busbars,
- TS35 mounting busbars,
- solid cables or cores of multicore cables,
- plates.

The current transformer can be mounted in any position. In order to mount a given type of transformer it should be drawn onto the busbar, next it should be fastened with the holders or mounting bolts to be found on both sides of the transformer. Mounting of the transformer on a plate, depending on the type, is made possible by two or four slides with which the device is furnished. A special base allows mounting on the TS35 mounting busbar. When mounting a transformer equipped with its own busbar, it should be fastened to the current circuit with the supplied bolt terminals with which the transformer busbar is furnished.

Low voltage current transformers cannot be used as support elements for current busbars (they cannot replace support insulators).

Details of mounting possibilities are indicated in the transformer selection table (page 52) and in the Accessories chapter (page 50).

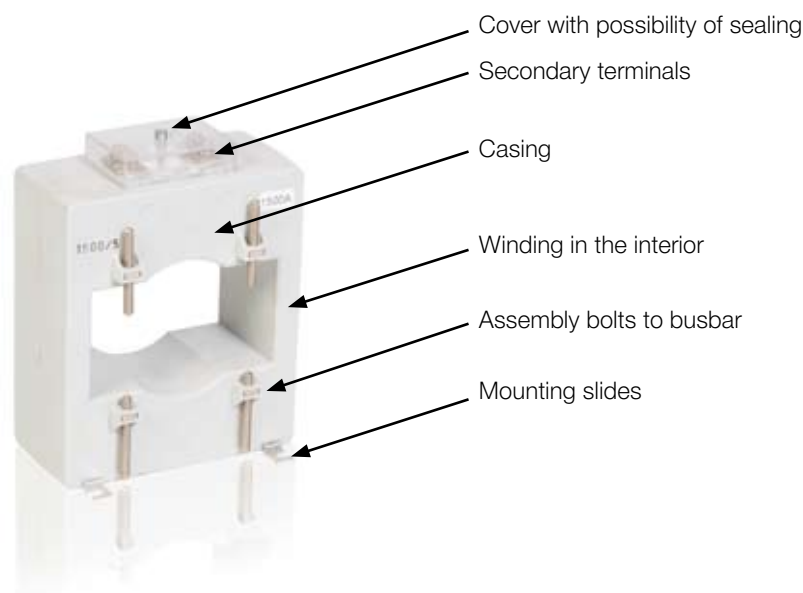

# General information

## Packing, transport, storage

Current transformers transported over significant distances should be packed in wooden crates, that protect the devices from damage. Transformers transported for short distances can be transported by truck without packing, but should be protected from damage by separating them from other products. During loading and unloading, crates with transformers must not be thrown or turned over. Wooden crates should be appropriately marked, in accordance with requirements concerning transport of products susceptible to mechanical damage. Transformers should be stored in dry and clean locations at temperatures close to 20°C. Storage of transformers in wooden crates outdoors is not recommended. Waste packing material should be recycled utilised in suitable plants.

## Spare parts

Current transformers are unreparable devices. No spare parts are provided.

## Compliance with standards

- PN-EN 60044-1,
- IEC 60044-1,
- DIN-EN 60044-1.

Transformers have IEL attestations and PTB approval.

## Warranty

The manufacturer grants a 24 month warranty for purchased transformers from the date of commissioning, however not longer than 30 months from the delivery date. The manufacturer is not liable for defects and damages arising as the result of: incorrect transport after receipt of transformers by the Ordering Party incorrect storage, installation and operation of transformers, inappropriate selection of transformers for a specific electric system.

## Handling used products

Due to the materials and technology used in their manufacture, transformers do not present a hazard to the environment. The used or damaged product should be disassembled, segregating parts of steel, non-ferrous metals, plastic and rubber. Segregated parts should be recycled or utilised at appropriate plants.

## Submitting an order

In order to submit an order the following data should be stated:

- transformer type,
- ratio -  $I_{pn}/I_{sn}$ ,  
 $I_{pn}$  - primary current,  
 $I_{sn}$  - secondary current,
- power in VA - MV,
- accuracy class,
- safety coefficient FS5 or FS10,
- climate in which the transformer will be installed: (moderate, tropical) - moderate is assumed by default,
- number of ordered pieces.

## Example of order:

Low voltage current transformer type IMSc, ratio 600/5 A/A; power 10 VA; class 0.5; FS5; pieces 300

## Simplified notation

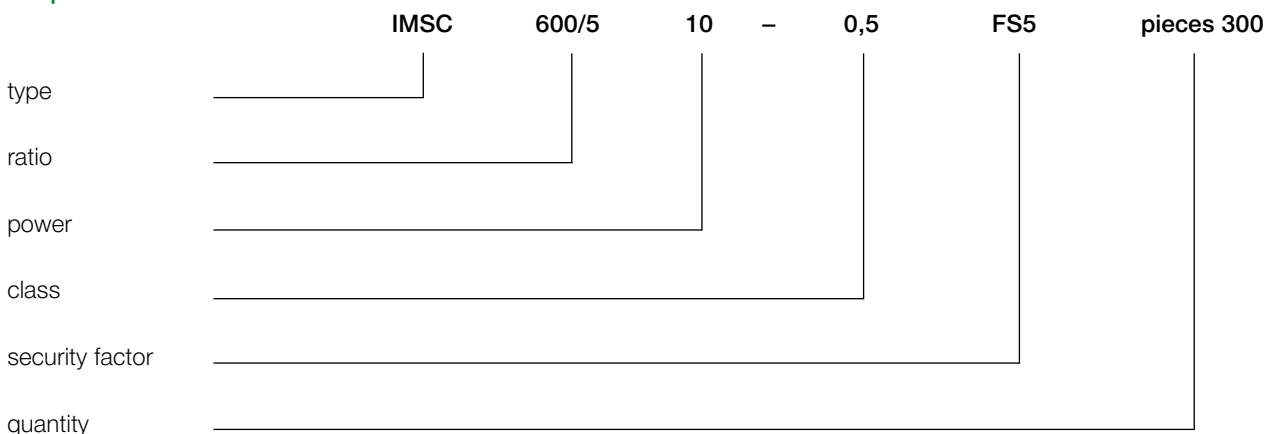

# Transformer selection

In matching the current transformer with a measurement system a number of key factors must be considered.

## Primary current to be converted by the transformer

The nominal value of the primary current ( $I_{pn}$ ) should be selected from the offered series range of available types to provide the closest match with the expected primary current of the system.

All low voltage transformers produced by ABB have an extended rating of 120% which makes conversion possible within a range 20% higher than the rated value.

## Secondary current

To adapt to the system found on the secondary side of the transformer.

5 A and 1 A are standardised values.

Note: primary current/secondary current ( $I_{pn}/I_{sn}$ ) is the standard transformer ratio.

## Power – the transformer load

The total load that will be connected to the transformer should be considered, including the load from the connected device as well as losses on connection leads and terminals. According to the standard IEC 60044-1 the current and angle errors of the transformer should not exceed values given in table 1 at any secondary load in the range from 25% to 100% of the rated load.

## Dimensions of the transformer internal opening and external dimensions

Specified to ensure that it is possible to install the transformer on the current circuit and that it can be accommodated in the planned locations.

## Selection of accuracy class to obtain satisfactory measurement accuracy

In many systems, transformer applications can be analysed according to class 0.2S or 0.5S. It is then possible to obtain more accurate current conversion of values significantly lower than the transformer rated value, up to 1% of the rated current value.

Table 1. Limits of current and phase errors of current transformers acc. to IEC 60044-1

Accuracy class	% $I_{pn}$ – percent of rated primary current									
	1	5	20	100	120	1	5	20	100	120
	Current error in percent +- percent					Angle error +- minutes				
0.2	-	0.75	0.35	0.2	0.2	-	30	15	10	10
0.5	-	1.5	0.75	0.5	0.5	-	90	45	30	30
0.2S	0.75	0.35	0.2	0.2	0.2	30	15	10	10	10
0.5S	1.5	0.75	0.5	0.5	0.5	90	45	30	30	30
1	-	3	1.5	1	1	-	180	90	60	60

Fig. 1. Accuracy class characteristics:

a) classes 0.2; 0.5; 1

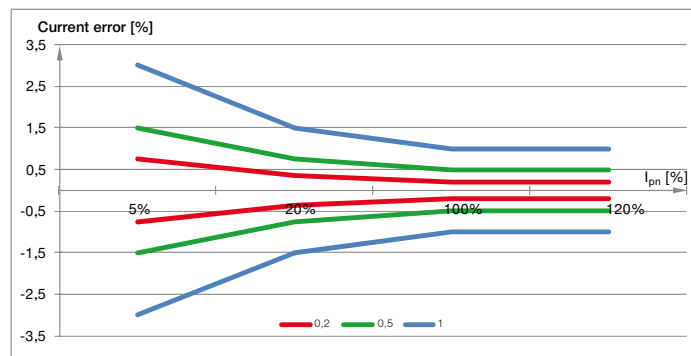

b) comparison of classes 0.5 and 0.5S

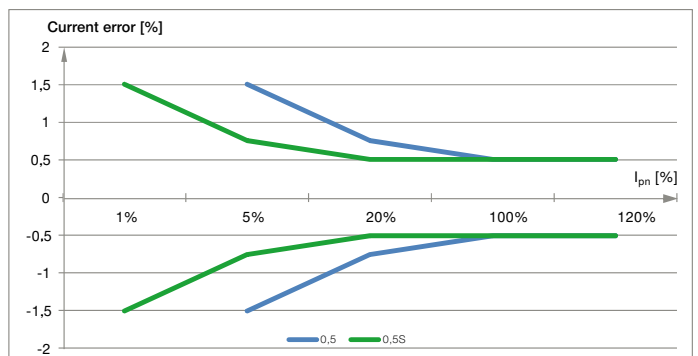

# Transformers type IMW with primary winding

Current transformers with their own primary wiring, intended for installation in supply system current circuits. Busbars or cables can be screwed to the primary terminals of these transformers. They allow high accuracy current conversion from the lowest values. Primary current range from 1 A to 300 A.



## Dimensional drawing

IMW – transformers with a flat outlet 20 x 5 mm

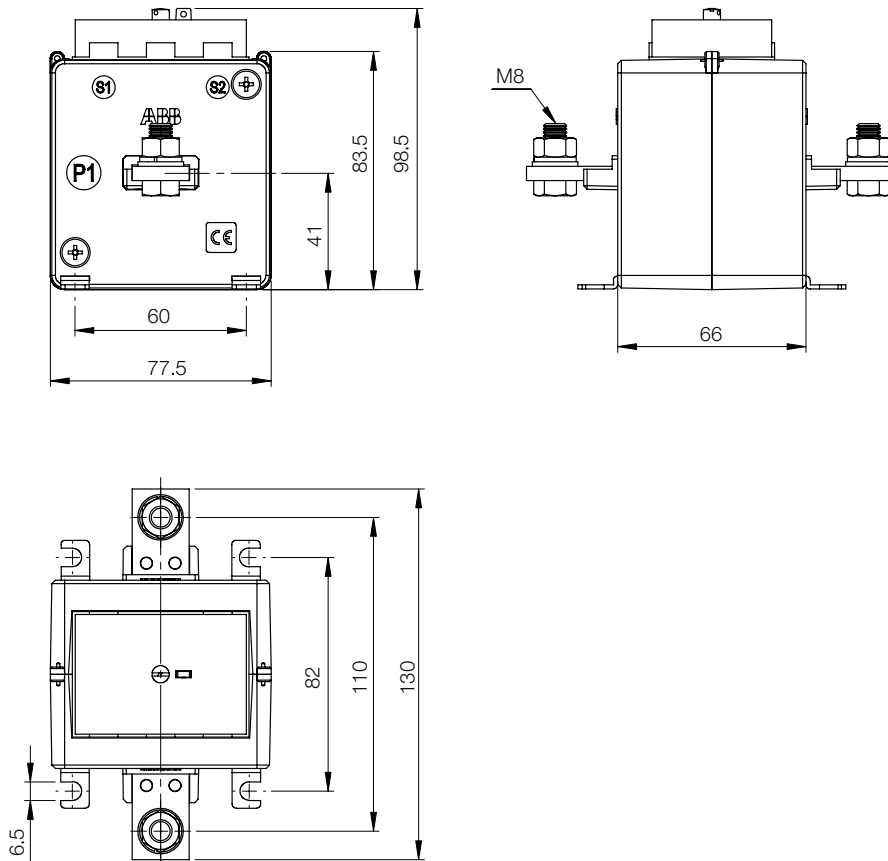

Type	Class	I <sub>pn</sub> [A]	I <sub>sn</sub> [A]	Security factor FS						Rated operation current		Maximum permissible voltage U <sub>m</sub> [kV]	Rated test voltage U <sub>p</sub> [kV]	Weight (approx.) [kg]
				Burden						short-time thermal I <sub>th</sub> [A]	peak I <sub>dyn</sub> [A]			
				2.5 [VA]	5 [VA]	7.5 [VA]	10 [VA]	15 [VA]	20 [VA]					
IMW	0.2S	5; 75	5							60xI <sub>pn</sub>	150xI <sub>pn</sub>	0.72	3	0.8
		100; 150		5; 10										
		250; 300												
	0.5S	5		5; 10										
		20; 30				5; 10								
		50; 75	5	5; 10	5; 10	5; 10	5; 10							
		100; 150												
		200		10	5; 10									
	0.2	250; 300		5; 10	5; 10	5; 10	5; 10							
		1; 2; 3; 5	5 or 1											
		10; 15; 20			10									
		25; 30; 40												
		50		5; 10	5; 10									
		75		5; 10	5; 10	5; 10								
		100		5; 10	5; 10	5; 10	5; 10							
125; 150	5; 10	5; 10		5; 10	5; 10									
0.5	200; 250	5	5; 10	5; 10	5; 10									
	300		5; 10	5; 10	5; 10	5; 10								
	1; 2; 3; 5	5 or 1												
	10; 15; 20			10	5; 10	5; 10	5; 10	5; 10						
	25; 30; 40													
50; 60	5; 10		5; 10	5; 10	5; 10	5; 10								
75; 100	5; 10		5; 10	5; 10	5; 10	5; 10								
1; 3	125; 150													
	200; 250		5; 10	5; 10	5; 10	5; 10	5; 10							
	300		5; 10	5; 10	5; 10	5; 10	5; 10							
	1; 2; 3; 5	5 or 1												
	10; 15; 20			10	5; 10	5; 10	5; 10	5; 10						
25; 30; 40														
50; 60; 75	5; 10		5; 10	5; 10	5; 10	5; 10								
100; 125	5; 10		5; 10	5; 10	5; 10	5; 10								
150; 200														
250; 300														

It is possible to order transformers of other parameters after prior arrangement with the manufacturer.

# Transformers type IMSa

Current transformers designed for placing on current busbars of maximum dimensions 40 × 10 mm.  
Primary current range from 150 A to 600 A.



## Dimensional drawing

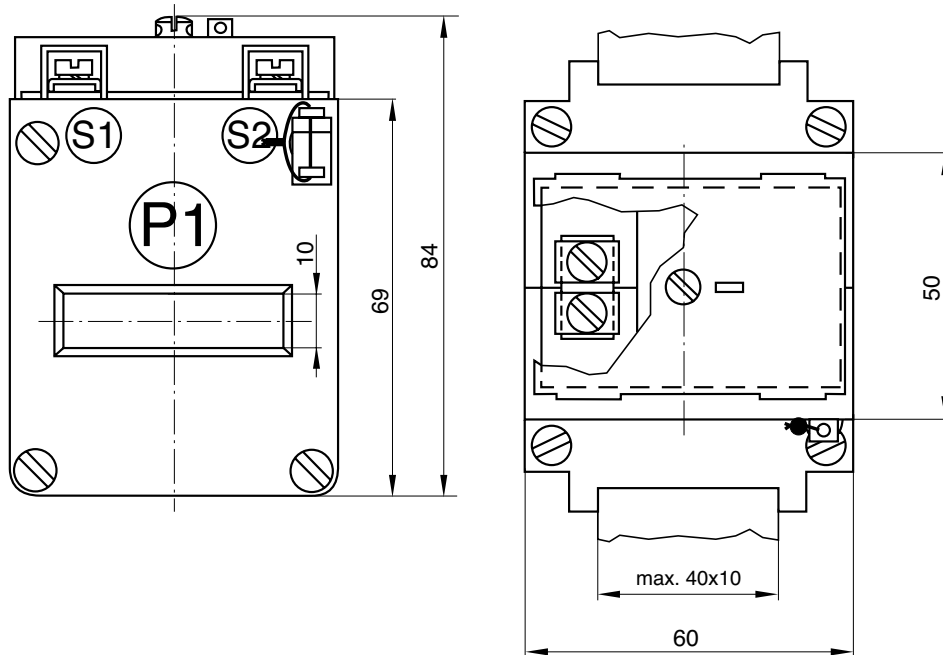



Type	Class	I <sub>pn</sub> [A]	I <sub>sn</sub> [A]	Security factor FS						Rated operation current		Maximum permissible voltage U <sub>m</sub> [kV]	Rated test voltage U <sub>p</sub> [kV]	Weight (approx.) [kg]
				Burden						short-time thermal I <sub>th</sub> [A]	peak I <sub>dyn</sub> [A]			
				2.5 [VA]	5 [VA]	7.5 [VA]	10 [VA]	15 [VA]	20 [VA]					
IMSa	0.2S	500	5	5; 10	10					60xI <sub>pn</sub>	150xI <sub>pn</sub>	0.72	3	0.45
		600			5; 10									
	0.5S	250			5; 10									
		300			5; 10									
		400	5		5; 10	5; 10								
	0.2	500	5		5; 10	10	5; 10							
		600			5; 10	5; 10	5; 10	5; 10						
		250			10									
	0.5	300	5		5; 10	5; 10								
		400	5		5; 10	5; 10	5; 10							
		500	5		5; 10	5; 10	5; 10	5; 10						
	1; 3	600	5		5; 10	5; 10	5; 10	5; 10	5; 10					
		150			5; 10	5; 10								
		200	5		5; 10	5; 10	5; 10							
		250	or		5; 10	5; 10	5; 10	5; 10						
		300	1		5; 10	5; 10	5; 10	5; 10	5; 10					
		400			5; 10	5; 10	5; 10	5; 10	5; 10					
	500			5; 10	5; 10	5; 10	5; 10	5; 10						
	600	5		5; 10	5; 10	5; 10	5; 10	5; 10						

It is possible to order transformers of other parameters after prior arrangement with the manufacturer.

# Transformers type IMSb

Current transformers designed for placing on current busbars of maximum dimensions 60 × 10 mm.  
Primary current range from 400 A to 1000 A.



## Dimensional drawing

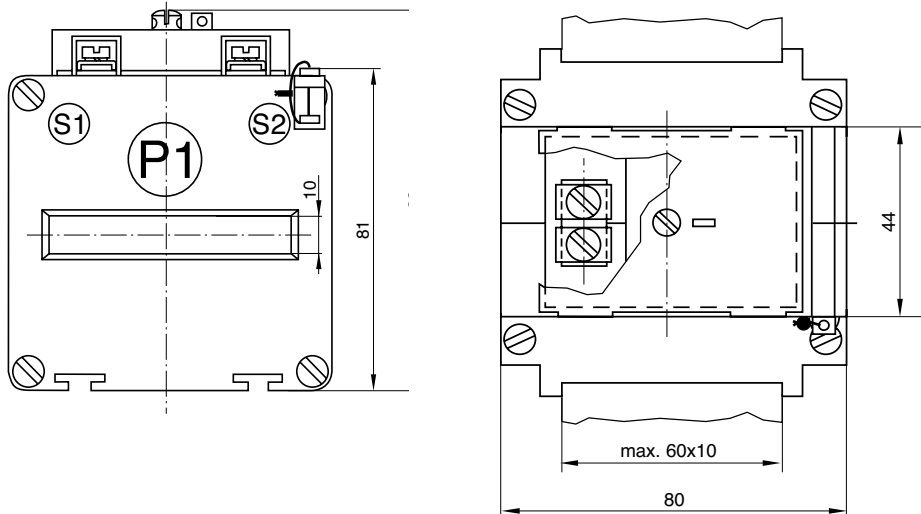

Type	Class	I <sub>pn</sub> [A]	I <sub>sn</sub> [A]	Security factor FS						Rated operation current		Maximum permissible voltage U <sub>m</sub> [kV]	Rated test voltage U <sub>p</sub> [kV]	Weight (approx.) [kg]		
				Burden						short-time thermal I <sub>th</sub> [A]	peak I <sub>dyn</sub> [A]					
				2.5 [VA]	5 [VA]	7.5 [VA]	10 [VA]	15 [VA]	20 [VA]							
IMSb	0.2S	600			5; 10											
		800	5		10											
		1000				5; 10										
	0.5S	500			5; 10	5; 10										
		600				5; 10	10	5; 10								
		750	5		5; 10	5; 10										
		800			5; 10	5; 10										
		1000				5; 10	5; 10	5; 10	5; 10	5; 10						
		0.2	400			5; 10	5; 10									
	500				5; 10	5; 10										
	600		5		5; 10	5; 10	5; 10	5; 10	5; 10							
	750				5; 10	5; 10	5; 10	5; 10	5; 10							
	800				5; 10	5; 10	5; 10	5; 10	5; 10							
	1000					5; 10	5; 10	5; 10	5; 10							
	600					5; 10	5; 10	5; 10	5; 10							
	750		1			10	5; 10	5; 10	5; 10							
	800					10	5; 10	5; 10	5; 10							
	1000					10	10	5; 10	5; 10							
	0.5	400			5; 10	5; 10	5; 10	5; 10								
		500			5; 10	5; 10	5; 10	5; 10	5; 10							
		600	5		5; 10	5; 10	5; 10	5; 10	5; 10	5; 10						
		750			5; 10	5; 10	5; 10	5; 10	5; 10	5; 10	5; 10					
		800			5; 10	5; 10	5; 10	5; 10	5; 10	5; 10	5; 10					
		1000				5; 10	5; 10	5; 10	5; 10	5; 10	5; 10					
		400			10	5; 10	5; 10	5; 10	5; 10							
		500			10	5; 10	5; 10	5; 10	5; 10							
		600	1			5; 10	5; 10	5; 10	5; 10	5; 10						
		750				5; 10	5; 10	5; 10	5; 10	5; 10	5; 10					
	800				10	5; 10	5; 10	5; 10	5; 10	5; 10						
	1000				10	10	5; 10	5; 10	5; 10	5; 10						
	1; 3	400			5; 10	5; 10	5; 10	5; 10								
		500			5; 10	5; 10	5; 10	5; 10	5; 10							
		600	5		5; 10	5; 10	5; 10	5; 10	5; 10	5; 10						
		750	or		5; 10	5; 10	5; 10	5; 10	5; 10	5; 10	5; 10					
		800	1		5; 10	5; 10	5; 10	5; 10	5; 10	5; 10	5; 10					
		1000				5; 10	5; 10	5; 10	5; 10	5; 10	5; 10					

It is possible to order transformers of other parameters after prior arrangement with the manufacturer.

# Transformers type IMSc

Current transformers designed for placing on current busbars of maximum dimensions  $80 \times 10$  mm.  
Primary current range from 400 A to 2500 A.



## Dimensional drawing

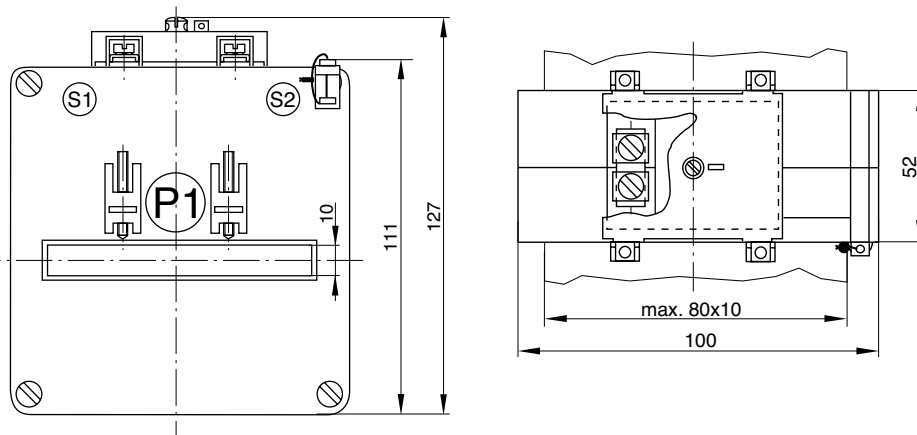

Type	Class	I <sub>pn</sub> [A]	I <sub>sn</sub> [A]	Security factor FS							Rated operation current		Maximum permissible voltage U <sub>m</sub> [kV]	Rated test voltage U <sub>p</sub> [kV]	Weight (approx.) [kg]	
				Burden							short-time thermal I <sub>th</sub> [A]	peak I <sub>dyn</sub> [A]				
				2.5 [VA]	5 [VA]	7.5 [VA]	10 [VA]	15 [VA]	20 [VA]	30 [VA]						
IMSc	0.2S	1000			10											
		1200			10						60xI <sub>pn</sub>	150xI <sub>pn</sub>				
		1500	5		10											
		2000			10	10										
		2500				10	10				100 kA	250 kA				
	0.5S	400			10											
		800				5; 10										
		1000				5; 10	5; 10	5; 10								
		1200	5			5; 10	5; 10	5; 10								
		1500				5; 10	5; 10	5; 10	5; 10							
		2000				10	10	10								
	0.2	400	5	5; 10												
		600			5; 10											
		750			5; 10											
		800			5; 10	5; 10										
		1000	5 or 1		5; 10	5; 10	5; 10	5; 10	5; 10	5; 10						
		1200			10	10	5; 10	5; 10	5; 10							
		1500			10	10	10	10								
		1600			10	10	10	10								
		2000			10	10	10	10								
		2500	5			10	10	5; 10	5; 10		100 kA	250 kA				
	0.5	400	5	5; 10	5; 10	5; 10	5; 10									
		500		5; 10	5; 10	5; 10	5; 10									
		600			5; 10	5; 10	5; 10									
		750			5; 10	5; 10	5; 10	5; 10								
		800	5		5; 10	5; 10	5; 10	5; 10								
		1000	5 or 1	10	5; 10	5; 10	5; 10	5; 10	5; 10	5; 10	5; 10					
		1200			5; 10	5; 10	5; 10	5; 10	5; 10	5; 10	5; 10					
		1500			5; 10	5; 10	5; 10	5; 10	5; 10							
		1600			10	10	5; 10	5; 10	5; 10							
		2000			10	10	10	5; 10	5; 10							
	1; 3	400		5; 10	5; 10	5; 10	5; 10									
		500		5; 10	5; 10	5; 10	5; 10	5; 10	5; 10							
		600		10	5; 10	5; 10	5; 10	5; 10	5; 10							
		750		10	5; 10	5; 10	5; 10	5; 10	5; 10							
		800	5 or 1	10	5; 10	5; 10	5; 10	5; 10	5; 10							
		1000		10	5; 10	5; 10	5; 10	5; 10	5; 10	5; 10						
		1200		10	5; 10	5; 10	5; 10	5; 10	5; 10	5; 10	5; 10					
		1500			5; 10	5; 10	5; 10	5; 10	5; 10							
		1600			10	10	5; 10	5; 10	5; 10							
		2000			10	10	10	5; 10	5; 10							
		2500	5			10	10	5; 10	5; 10		100 kA	250 kA				

It is possible to order transformers of other parameters after prior arrangement with the manufacturer.

# Transformers type IMSd

Current transformers designed for placing on current busbars of maximum dimensions 120 x 30 mm or 100 x 50 mm. Also allows a cable of maximum 85 mm diameter to be pulled through. The transformer allows conversion of high currents and high powers. Can perform measurement class and protection class functions.



## Dimensional drawing

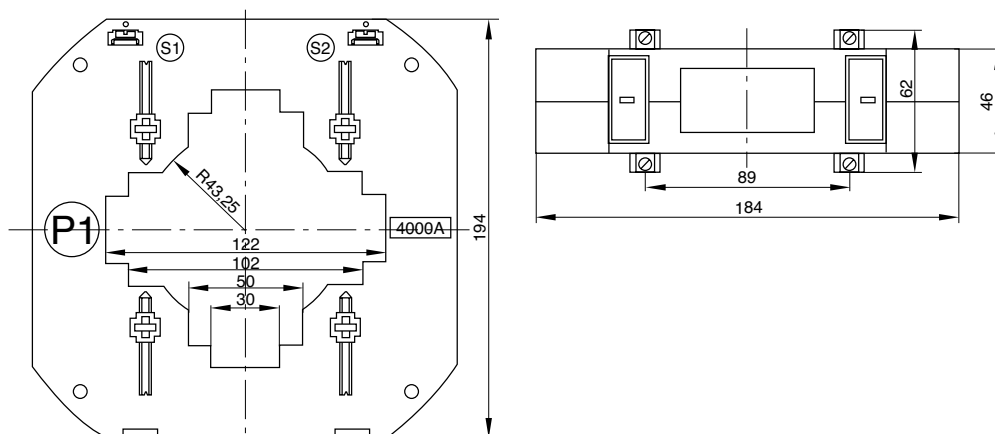

Type	Class	I <sub>pn</sub> [A]	I <sub>sn</sub> [A]	Security factor FS										Rated operation current		Maximum permissible voltage U <sub>m</sub> [kV]	Rated test voltage U <sub>p</sub> [kV]	Weight (approx.) [kg]		
				Burden										short-time thermal I <sub>th</sub> [kA]	peak I <sub>dyn</sub> [kA]					
				5 [VA]	7.5 [VA]	10 [VA]	15 [VA]	20 [VA]	30 [VA]	45 [VA]	60 [VA]	90 [VA]	120 [VA]							
IMSD	0.2S	2500	5		10										62.5	156.5	0.72	3	1.8	
		3000		10	10	10	10	10	5; 10						75	187				
	1000			10										37.5	100					
	1600			5; 10										40	105					
	0.5S	2000			5; 10	5; 10	5; 10	5; 10	5; 10						50	125				
		2500	5		10	5; 10	5; 10	5; 10	5; 10						62.5	156.5				
		3000		10	10	5; 10	5; 10	5; 10	5; 10					75	187					
		4000			10	10	10	5; 10	5; 10	5; 10	5; 10				100	250				
	5000				10	5; 10	5; 10	5; 10												
	0.2	1000	5		10	10														
		1200		10	10	10									37.5	100				
		1500		10	5; 10	5; 10														
		1600		10	5; 10	5; 10										40				105
		2000		10	5; 10	5; 10	5; 10									50				125
		2500		or 1	10	10	5; 10	5; 10	5; 10	5; 10						62.5				156.5
		3000			10	10	10	5; 10	5; 10	5; 10	5; 10	5; 10				75				187
		4000			10	10	10	5; 10	5; 10	5; 10	5; 10	5; 10				100				250
		5000		5				10	5; 10	5; 10	5; 10									
		0.5		500		10														30
	600			10	10	5; 10									36	90				
	750			10	10	5; 10														
	800			10	10	5; 10														
	1000		5	10	5; 10	5; 10	5; 10								37.5	100				
	1200			10	5; 10	5; 10	5; 10													
	1500		or 1	10	5; 10	5; 10	5; 10	5; 10												
	1600			10	5; 10	5; 10	5; 10	5; 10	5; 10	5; 10					40	105				
	2000		10	5; 10	5; 10	5; 10	5; 10	5; 10	5; 10	5; 10	5; 10	5; 10			50	125				
	2500		10	10	5; 10	5; 10	5; 10	5; 10	5; 10	5; 10	5; 10	5; 10			62.5	156.5				
	3000	10	10	5; 10	5; 10	5; 10	5; 10	5; 10	5; 10	5; 10	5; 10			75	187					
	4000		10	10	10	5; 10	5; 10	5; 10	5; 10	5; 10	5; 10	5; 10		100	250					
	5000	5				10	5; 10	5; 10	5; 10	5; 10	5; 10									
	1; 3	500		10											30	75				
		600		5; 10	5; 10	5; 10									36	90				
		750		5; 10	5; 10	5; 10														
		800		5; 10	5; 10	5; 10														
		1000	5	5; 10	5; 10	5; 10	5; 10								37.5	100				
		1200		5; 10	5; 10	5; 10	5; 10													
		1500	or 1	5; 10	5; 10	5; 10	5; 10	5; 10	5; 10											
		1600		10	5; 10	5; 10	5; 10	5; 10	5; 10	5; 10					40	105				
		2000	10	5; 10	5; 10	5; 10	5; 10	5; 10	5; 10	5; 10	5; 10	5; 10			50	125				
2500		10	10	5; 10	5; 10	5; 10	5; 10	5; 10	5; 10	5; 10	5; 10			62.5	156.5					
3000	10	10	5; 10	5; 10	5; 10	5; 10	5; 10	5; 10	5; 10	5; 10			75	187						
4000		10	10	10	5; 10	5; 10	5; 10	5; 10	5; 10	5; 10	5; 10		100	250						
5000	5				10	5; 10	5; 10	5; 10	5; 10	5; 10	5; 10									

It is possible to order transformers of other parameters after prior arrangement with the manufacturer.  
There is a possibility of performing by special order transformers of primary current I<sub>pn</sub> up to 6000 A and protection classes.

# Transformers type IMPa

Current transformers for cables of maximum 20 mm diameter. The transformer is equipped with a holder enabling it to be assembled on current busbars of maximum dimensions 20 x 10 mm. Primary current range from 100 A to 300 A.



## Dimensional drawing

Supporting version

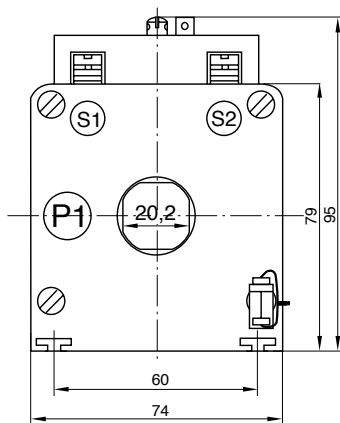

Seal wired version

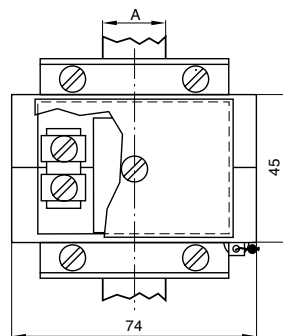
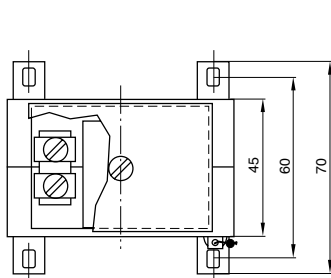
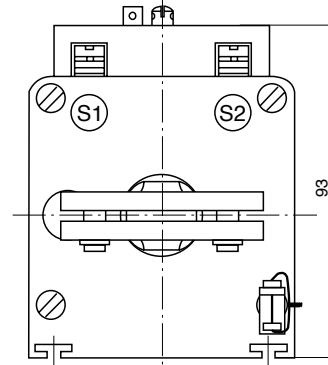



Type	Class	I <sub>pn</sub> [A]	I <sub>sn</sub> [A]	Security factor FS						Rated operation current		Maximum permissible voltage U <sub>m</sub> [kV]	Rated test voltage U <sub>p</sub> [kV]	Weight (approx.) [kg]	
				Burden						short-time thermal I <sub>th</sub> [A]	peak I <sub>dyn</sub> [A]				
				2.5 [VA]	5 [VA]	7.5 [VA]	10 [VA]	15 [VA]	20 [VA]						
IMPa	0.5S	200		10	5; 10	10	10								
		250	5	5; 10	5; 10	10	5; 10								
		300		5; 10	5; 10	5; 10	5; 10								
	0.2	200	5	10	10	10									
		250		5; 10	5; 10	5; 10									
		300		5; 10	10	10									
	0.5	100		10											
		125		10	5; 10										
		150		5; 10	5; 10	5; 10									
		200	5	5; 10	5; 10	5; 10	5; 10	10		60xI <sub>pn</sub>	150xI <sub>pn</sub>	0.72	3	0.8	
		250	or	5; 10	5; 10	5; 10	5; 10	10							
		300	1	5; 10	5; 10	5; 10	5; 10	5; 10	5; 10						
	1; 3	100		10	10										
		125		10	5; 10										
		150		5; 10	5; 10	5; 10	5; 10								
		200		5; 10	5; 10	5; 10	5; 10	10							
		250		5; 10	5; 10	5; 10	5; 10	10	10						
		300		5; 10	5; 10	5; 10	5; 10	5; 10	5; 10						

It is possible to order transformers of other parameters after prior arrangement with the manufacturer.

# Transformers type IMPb

Current transformers for cables of maximum 30 mm diameter.  
The transformer is equipped with a holder for assembly on current busbars of maximum dimensions 30 x 10 mm.  
Primary current range from 100 A to 600 A.



## Dimensional drawing

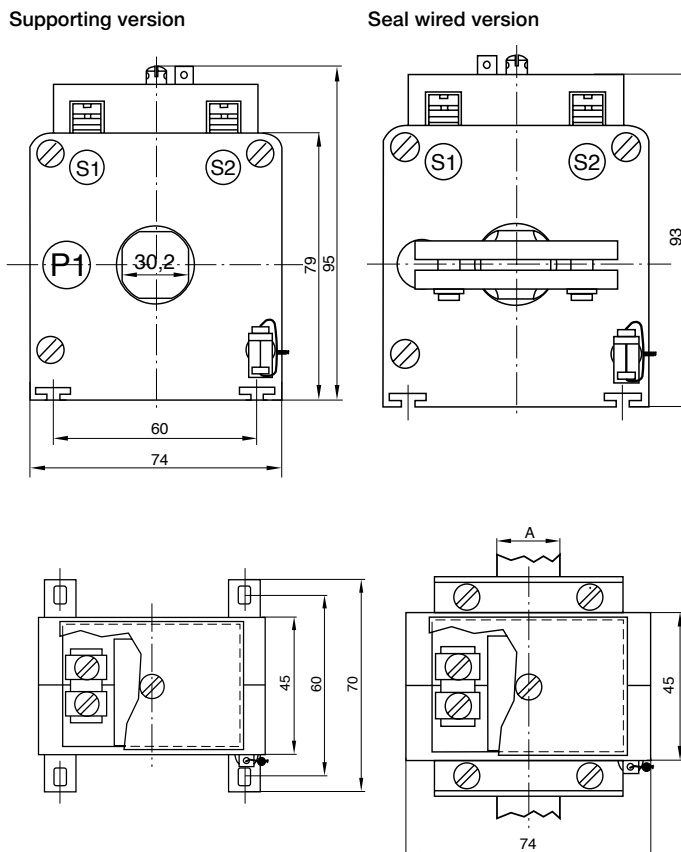

Type	Class	I <sub>pn</sub> [A]	I <sub>sn</sub> [A]	Security factor FS						Rated operation current		Maximum permissible voltage U <sub>m</sub> [kV]	Rated test voltage U <sub>p</sub> [kV]	Weight (approx.) [kg]	
				Burden						short-time thermal I <sub>th</sub> [A]	peak I <sub>dyn</sub> [A]				
				2.5 [VA]	5 [VA]	7.5 [VA]	10 [VA]	15 [VA]	20 [VA]						
IMPb	0.2S	250			5; 10										
		300	5		10										
		400		5; 10	5; 10	5; 10	5; 10								
	0.5S	200			5; 10										
		250		10	5; 10	10	5; 10								
		300	5	10	5; 10	5; 10	5; 10	5; 10							
		400		5; 10	5; 10	5; 10	5; 10	5; 10							
		500			5; 10	5; 10	5; 10								
	0.2	250	5	10	5; 10										
		300	or	10	5; 10	5; 10	5; 10	5; 10							
		400	1	5; 10	5; 10	5; 10	5; 10	5; 10							
		500	5	5; 10	5; 10	5; 10									
	0.5	150		10											
		200	5	10	5; 10	5; 10					60xI <sub>pn</sub>	150xI <sub>pn</sub>	0.72	3	0.5
		250	or	10	5; 10	5; 10	5; 10	5; 10							
		300	1	5; 10	5; 10	5; 10	5; 10	5; 10	5; 10						
		400		5; 10	5; 10	5; 10	5; 10	5; 10	5; 10	5; 10					
	1; 3	500	5	5; 10	5; 10	5; 10	5; 10	5; 10	5; 10	5; 10					
		100		10											
		150		10	10										
		200	5	10	10	5; 10	10	10							
		250	or	10	5; 10	5; 10	5; 10	10							
		300	1	5; 10	5; 10	5; 10	5; 10	5; 10	5; 10						
		400		5; 10	5; 10	5; 10	5; 10	5; 10	5; 10	5; 10					
500		5	5; 10	5; 10	5; 10	5; 10	5; 10	5; 10	5; 10						
600			10	10	5; 10	5; 10	5; 10								

It is possible to order transformers of other parameters after prior arrangement with the manufacturer.

# Transformers type ISWb

Current transformers for a cable of maximum 48 mm diameter or a busbar of maximum 60 × 30 mm dimensions.  
Primary current range from 250 A to 1600 A.



## Dimensional drawing

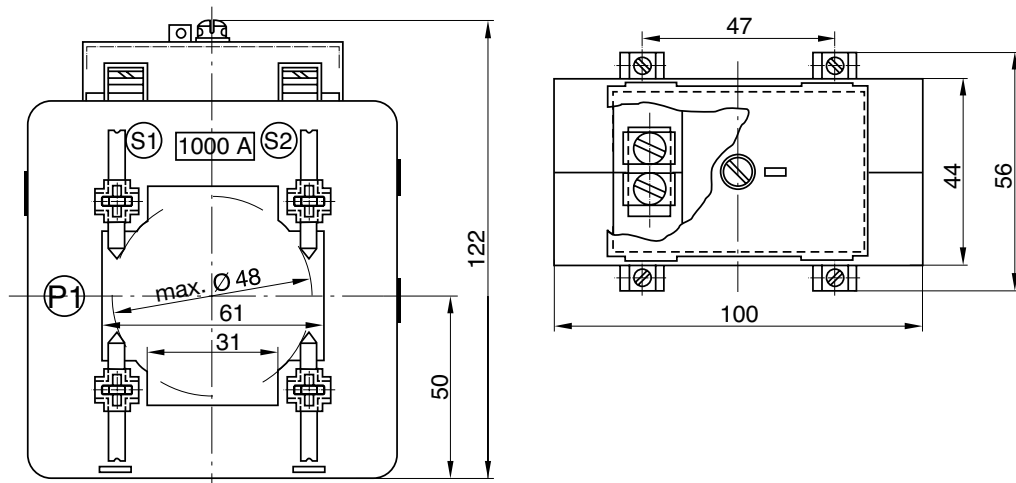

Type	Class	I <sub>pn</sub> [A]	I <sub>sn</sub> [A]	Security factor FS							Rated operational		Maximum permissible voltage U <sub>m</sub> [kV]	Rated test voltage U <sub>p</sub> [kV]	Weight (approx.) [kg]
				Burden							short-time thermal I <sub>th</sub> [A]	peak I <sub>dyn</sub> [A]			
				2.5 [VA]	5 [VA]	7.5 [VA]	10 [VA]	15 [VA]	20 [VA]	30 [VA]					
ISWb	0.2S	1200	5			5; 10									
	0.5S	600	5		5; 10	5; 10	5; 10								
		1000			5; 10	5; 10	5; 10								
		1200			10	5; 10	5; 10	5; 10							
		1500			10	5; 10	5; 10	5; 10	5; 10						
		500			5; 10										
	0.2	600	5		5; 10										
		1000			10	5; 10									
		1200			10	5; 10	5; 10								
		250			5; 10										
	0.5	300	5		5; 10	5; 10									
		400			5; 10	5; 10	5; 10								
		500			5; 10	5; 10	5; 10	5; 10							
		600			5; 10	5; 10	5; 10	5; 10	5; 10						
		750			5; 10	5; 10	5; 10	5; 10	5; 10						
		800			5; 10	5; 10	5; 10	5; 10	5; 10						
		1000			5; 10	5; 10	5; 10	5; 10	5; 10	5; 10	5; 10				
		1200			10	5; 10	5; 10	5; 10	5; 10	5; 10	5; 10	5; 10			
		1500				5; 10	5; 10	5; 10	5; 10	5; 10	5; 10	5; 10			
		1600			5		5; 10	5; 10	5; 10	5; 10	5; 10	5; 10			
	1; 3	250	5 or 1		5; 10	5; 10									
		300			5; 10	5; 10									
		400			5; 10	5; 10	5; 10	5; 10							
		500			5; 10	5; 10	5; 10	5; 10	5; 10						
		600			5; 10	5; 10	5; 10	5; 10	5; 10						
		750			5; 10	5; 10	5; 10	5; 10	5; 10						
		800			5; 10	5; 10	5; 10	5; 10	5; 10	5; 10					
		1000			5; 10	5; 10	5; 10	5; 10	5; 10	5; 10	5; 10				
		1200			10	5; 10	5; 10	5; 10	5; 10	5; 10	5; 10	5; 10			
		1500				5; 10	5; 10	5; 10	5; 10	5; 10	5; 10	5; 10			
1600					5; 10	5; 10	5; 10	5; 10	5; 10	5; 10	5; 10				

It is possible to order transformers of other parameters after prior arrangement with the manufacturer.

# Transformers type ISWb2

Current transformers designed for mounting on current busbars of maximum dimensions 75 x 30 mm.  
Primary current range from 500 A to 1200 A.



## Dimensional drawing

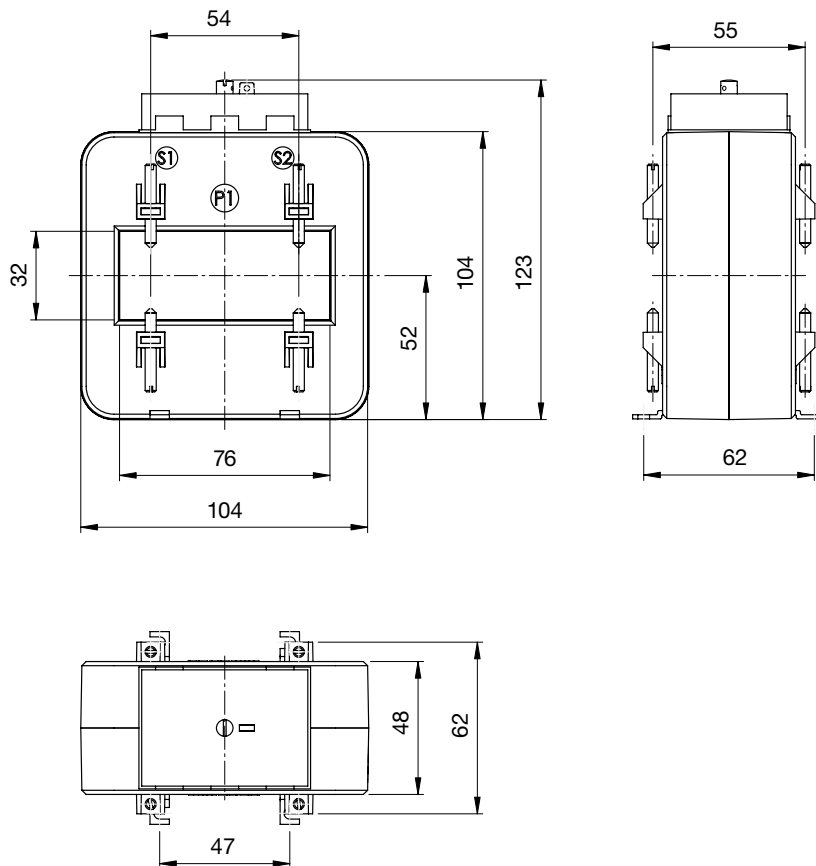

Type	Class	I <sub>pn</sub> [A]	I <sub>sn</sub> [A]	Security factor FS						Rated operation current		Maximum permissible voltage U <sub>m</sub> [kV]	Rated test voltage U <sub>p</sub> [kV]	Weight (approx.) [kg]	
				Burden						short-time thermal I <sub>th</sub> [A]	peak I <sub>dyn</sub> [A]				
				2.5 [VA]	5 [VA]	7.5 [VA]	10 [VA]	15 [VA]	20 [VA]						
ISWb2	0.5S	600		10											
		750		10	10	5; 10									
		800	5	10	10	5; 10	5; 10								
		1000		10	10	5; 10	5; 10	5; 10							
		1200		10	10	5; 10	5; 10	5; 10	5; 10						
	0.2	750	5	10	10	5; 10									
		800	or	10	10	10									
		1000	1	10	10	5; 10	5; 10								
		1200	5	10	10	5; 10	5; 10	5; 10	5; 10						
	0.5	500		10	10										
		600	5	10	10	5; 10	5; 10			60xI <sub>pn</sub>	150xI <sub>pn</sub>	0.72	3	0.7	
		750	or	10	10	5; 10	5; 10								
		800	1	10	10	5; 10	5; 10	5; 10							
		1000		10	10	5; 10	5; 10	5; 10	5; 10						
		1200	5	10	10	5; 10	5; 10	5; 10	5; 10						
	1; 3	500		10	10	5; 10	5; 10								
		600	5	10	10	5; 10	5; 10								
		750	or	10	10	5; 10	5; 10								
		800	1	10	10	5; 10	5; 10	5; 10							
		1000		10	10	5; 10	5; 10	5; 10	5; 10						
		1200	5	10	10	5; 10	5; 10	5; 10	5; 10						

It is possible to order transformers of other parameters after prior arrangement with the manufacturer.

# Transformers type ISWc

Current transformers designed for mounting on current busbars of maximum dimensions 40 x 10 mm and a cable of maximum 30 mm diameter. Primary current range from 75 A to 500 A. The special transformer window shape allows various busbar locations.



## Dimensional drawing

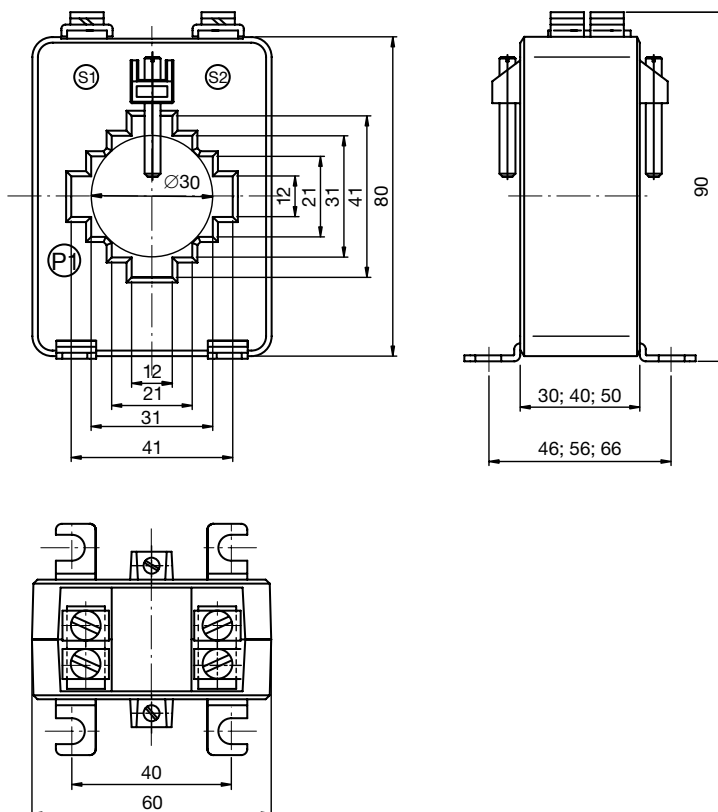



Type	Class	I <sub>pn</sub> [A]	I <sub>sn</sub> [A]	Security factor FS								Rated operation current		Maximum permissible voltage U <sub>m</sub> [kV]	Rated test voltage U <sub>p</sub> [kV]	Weight (approx.) [kg]		
				Burden								short-time thermal I <sub>th</sub> [A]	peak I <sub>dyn</sub> [A]					
				1 [VA]	2.5 [VA]	5 [VA]	7.5 [VA]	10 [VA]	15 [VA]	20 [VA]	25 [VA]							
ISWc	0.5S	300			5; 10													
		400	5		5; 10	5; 10												
		500			5; 10	5; 10	5; 10											
	0.2	300			10													
		400			5; 10													
		500			5; 10	5; 10	5; 10											
	0.5	150			10													
		200			10													
		250			10	5; 10												
		300			10	5; 10	5; 10	5; 10										
		400				5; 10	5; 10	5; 10	5; 10	5; 10								
		500				5; 10	5; 10	5; 10	5; 10	5; 10	5; 10	5; 10						
	1	150		5; 10	5; 10													
		200	5		10	5; 10	5; 10											
		250	or		10	5; 10	5; 10	5; 10										
		300	1		10	5; 10	5; 10	5; 10	5; 10									
		400				5; 10	5; 10	5; 10	5; 10	5; 10								
		500				5; 10	5; 10	5; 10	5; 10	5; 10	5; 10	5; 10						
	3	75			10	5; 10												
		100			10	5; 10												
		150			5; 10	5; 10	5; 10											
		200			10	5; 10	5; 10											
		250			10	5; 10	5; 10	5; 10										
		300			10	5; 10	5; 10	5; 10	5; 10									
400					5; 10	5; 10	5; 10	5; 10	5; 10									
500				5; 10	5; 10	5; 10	5; 10	5; 10	5; 10	5; 10								

It is possible to order transformers of other parameters after prior arrangement with the manufacturer.

# Transformers type ISWd1

Current transformers designed for mounting on current busbars of maximum dimensions 80 x 10 mm or 60 x 30 mm and a cable of maximum 55 mm diameter. Primary current range from 250 A to 1000 A. The special transformer window shape allows various busbar locations.



## Dimensional drawing

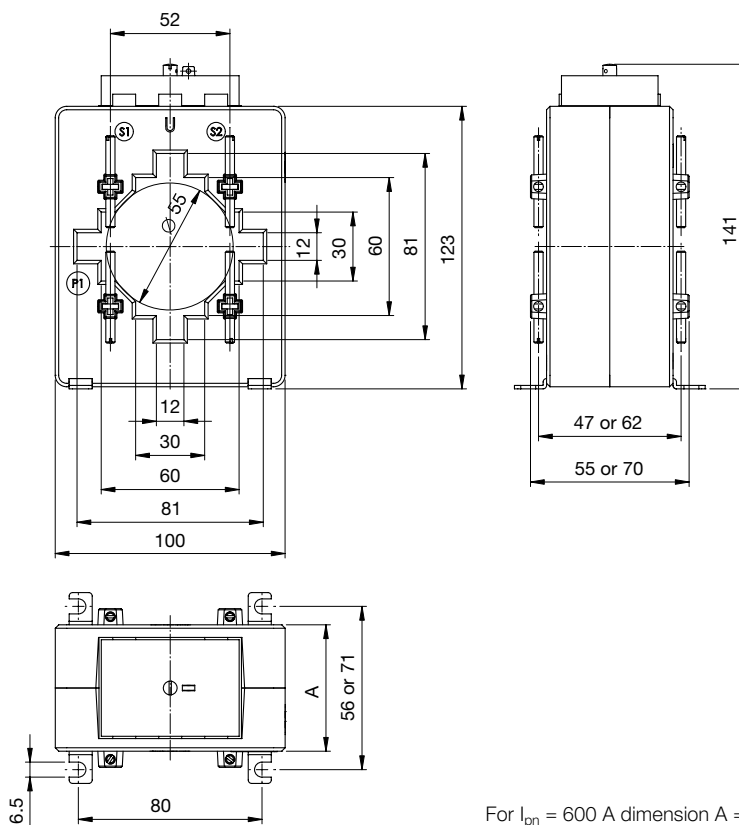

For  $I_{pn} = 600$  A dimension A = 40 mm  
For  $I_{pn} \neq 600$  A dimension A = 55 mm

Type	Class	I <sub>pn</sub> [A]	I <sub>sn</sub> [A]	Security factor FS					Rated operation current		Maximum permissible voltage U <sub>m</sub> [kV]	Rated test voltage U <sub>p</sub> [kV]	Weight (approx.) [kg]	
				Burden					short-time thermal I <sub>th</sub> [A]	peak I <sub>dyn</sub> [A]				
				2.5 [VA]	5 [VA]	7.5 [VA]	10 [VA]	15 [VA]						20 [VA]
ISWd1	0.5S	500	5	10						60xI <sub>pn</sub>	150xI <sub>pn</sub>	0.72	3	0.7
		600		10	5; 10									
		750		10	5; 10	5; 10	5; 10	5; 10						
		800		10	5; 10	5; 10	5; 10	5; 10						
		1000		10	5; 10	5; 10	5; 10	5; 10	5; 10					
	0.2	600	5 or 1	10										
		750		10	5; 10	5; 10								
		800		10	5; 10	5; 10								
		1000		10	5; 10	5; 10	5; 10							
	0.5	250	5 or 1	10										
		300		10										
		400		10	5; 10									
		500		10	5; 10	5; 10								
		600		10	5; 10	5; 10	5; 10							
		750		10	5; 10	5; 10	5; 10	5; 10						
		800		10	5; 10	5; 10	5; 10	5; 10						
		1000		10	5; 10	5; 10	5; 10	5; 10	5; 10					
		250		10	10									
		300		10	5; 10									
	1; 3	400	5 or 1	10	5; 10	5; 10	5; 10							
		500		10	5; 10	5; 10	5; 10							
		600		10	5; 10	5; 10	5; 10							
		750		10	5; 10	5; 10	5; 10							
		800		10	5; 10	5; 10	5; 10	5; 10						
1000		10		5; 10	5; 10	5; 10	5; 10	5; 10						

It is possible to order transformers of other parameters after prior arrangement with the manufacturer.

# Transformers type ISWd2

Current transformers designed for mounting on current busbars of maximum dimensions 80 x 30 mm (horizontal) or 60 x 30 mm (vertical) and a cable of maximum 55 mm diameter. Primary current range from 1000 A to 1600 A. The special transformer window shape allows various busbar locations.



## Dimensional drawing

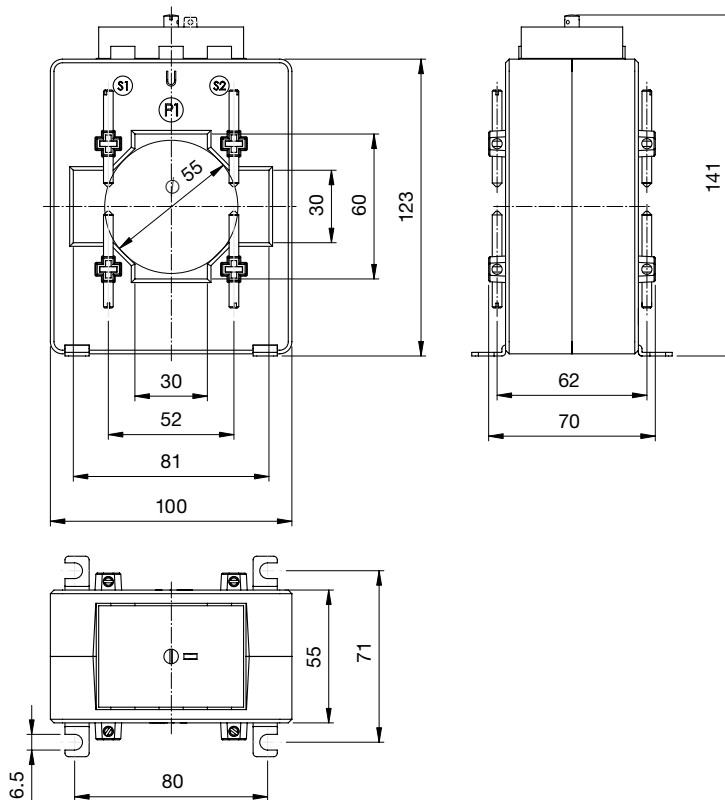

Type	Class	$I_{pn}$ [A]	$I_{sn}$ [A]	Security factor FS					Rated operation current		Maximum permissible voltage $U_m$ [kV]	Rated test voltage $U_p$ [kV]	Weight (approx.) [kg]
				Burden					short-time thermal $I_{th}$ [A]	peak $I_{dyn}$ [A]			
				2.5 [VA]	5 [VA]	7.5 [VA]	10 [VA]	15 [VA]					
ISWd2	0.5S	1000	5	10	5; 10				60x $I_{pn}$	150x $I_{pn}$	0.72	3	0.7
		1200		10	5; 10	5; 10	5; 10						
		1500		10	5; 10	5; 10	5; 10						
		1600		10	5; 10	5; 10	5; 10	5; 10					
	0.2	1200	5 or 1	10	5; 10	5; 10							
		1500		10	5; 10	5; 10							
		1600		10	5; 10	5; 10							
	0.5	1000	5	10	5; 10	5; 10							
		1200		10	5; 10	5; 10	5; 10						
		1500		10	5; 10	5; 10	5; 10	5; 10					
		1600		10	5; 10	5; 10	5; 10	5; 10					
	1; 3	1000	5 or 1	10	5; 10	5; 10							
		1200		10	5; 10	5; 10	5; 10						
		1500		10	5; 10	5; 10	5; 10	5; 10					
		1600		10	5; 10	5; 10	5; 10	5; 10					

It is possible to order transformers of other parameters after prior arrangement with the manufacturer.

# Transformers type ISWe

Current transformers designed for mounting on current busbars of maximum dimensions 120 x 30 mm.  
Primary current range from 400 A to 4000 A.



## Dimensional drawing

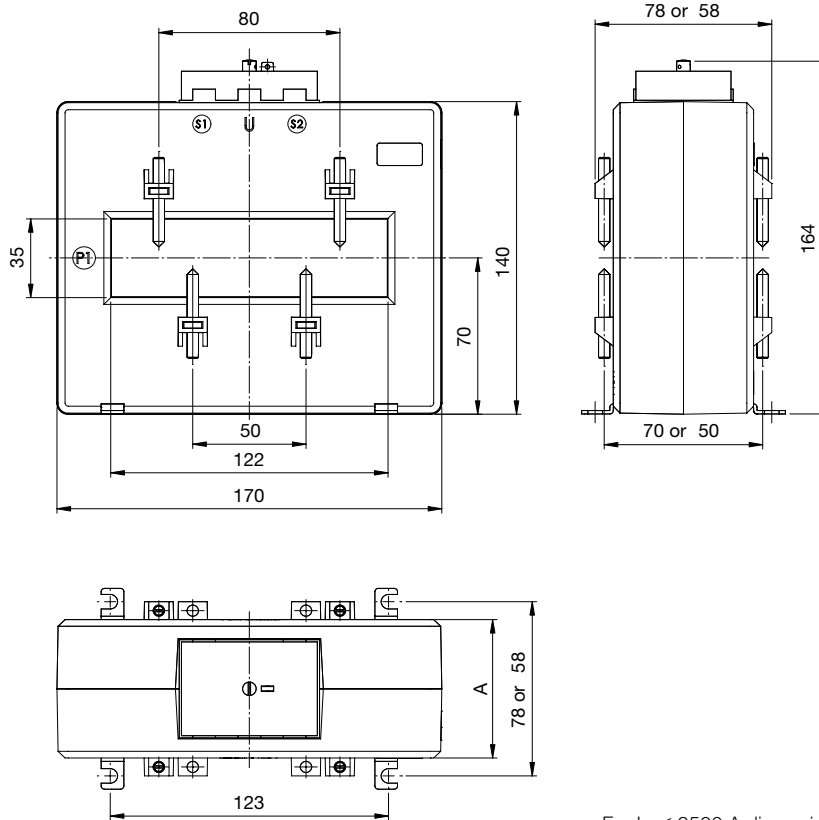

For  $I_{pn} \leq 2500$  A dimension A = 42 mm  
For  $I_{pn} > 2500$  A dimension A = 62 mm

Type	Class	I <sub>pn</sub> [A]	I <sub>sn</sub> [A]	Security factor FS										Rated operation current short-time thermal I <sub>th</sub> [A]	Maximum permissible voltage U <sub>m</sub> [kV]	Rated test voltage U <sub>p</sub> [kV]	Weight (approx.) [kg]			
				Burden														peak I <sub>dyn</sub> [A]		
				2.5 [VA]	5 [VA]	7.5 [VA]	10 [VA]	15 [VA]	20 [VA]	30 [VA]	45 [VA]	60 [VA]	75 [VA]							
ISWe	0.2S	1500			10										60xI <sub>pn</sub>	150xI <sub>pn</sub>				
		1600			10	10														
		2000	5		10	10	10	10												
		2500			10	10	10	10	10	10	5	10				100 kA	250 kA			
		3000			10	10	10	10	10	10	5	10								
		4000			10	10	10	10	10	10	5	10								
	0.5S	600		10	10											60xI <sub>pn</sub>	150xI <sub>pn</sub>			
		750		10	10	5	10													
		800		10	10	5	10	5	10											
		1000		10	10	10	5	10												
		1200		10	10	10	5	10												
		1500	5	10	10	10	5	10	5	10	5	10								
		1600		10	10	10	5	10	5	10	5	10								
		2000		10	10	10	10	10	10	10										
		2500		10	10	10	10	10	10	10	5	10	5	10						
		3000		10	10	10	10	10	10	10	5	10	5	10		100 kA	250 kA			
		4000		10	10	10	10	10	10	10	5	10	5	10						
		0.2	600		10	10											60xI <sub>pn</sub>	150xI <sub>pn</sub>		
	750			10	10															
	800			10	10	5	10													
	1000			10	10	10	5	10												
	1200		5	10	10	10	5	10												
	1500		or	10	10	10	5	10	5	10	5	10								
	1600		1	10	10	10	5	10	5	10	5	10								
	2000			10	10	10	10	10	5	10										
	2500			10	10	10	10	10	5	10	5	10								
	3000			10	10	10	10	10	5	10	5	10				100 kA	250 kA			
	4000			10	10	10	10	10	5	10	5	10								
	0.5		400		10												60xI <sub>pn</sub>	150xI <sub>pn</sub>		
		500		10	10															
		600		10	10	5	10													
		750		10	10	5	10	5	10											
		800		10	10	5	10	5	10	5	10									
		1000	5	10	10	10	5	10	5	10										
		1200	or	10	10	10	5	10	5	10										
		1500	1	10	10	10	5	10	5	10	5	10								
		1600		10	10	10	5	10	5	10	5	10								
		2000		10	10	10	10	10	5	10	5	10								
		2500		10	10	10	10	10	5	10	5	10								
		3000		10	10	10	10	10	5	10	5	10	5	10		100 kA	250 kA			
	4000		10	10	10	10	10	5	10	5	10	5	10							
	1; 3	400		10	10	5	10									60xI <sub>pn</sub>	150xI <sub>pn</sub>			
		500		10	10	5	10	10												
		600		10	10	5	10	5	10	5	10									
		750		10	10	5	10	5	10	5	10									
		800		10	10	5	10	5	10	5	10	5	10							
		1000	5	10	10	10	5	10	5	10	5	10								
		1200	or	10	10	10	5	10	5	10	5	10	5	10						
1500		1	10	10	10	5	10	5	10	5	10	5	10							
1600			10	10	10	5	10	5	10	5	10	5	10							
2000			10	10	10	10	10	5	10	5	10	5	10							
2500			10	10	10	10	10	5	10	5	10	5	10							
3000			10	10	10	10	10	5	10	5	10	5	10	5	10	100 kA	250 kA			
4000		10	10	10	10	10	5	10	5	10	5	10	5	10						

It is possible to order transformers of other parameters after prior arrangement with the manufacturer.  
There is a possibility of performing by special order transformers of primary current I<sub>pn</sub> up to 6000 A.

# Transformers type ISWf

Current transformers designed for mounting on current busbars of maximum dimensions 100 x 55 mm and a cable of maximum 70 mm diameter.

Primary current range from 500 A to 2500 A.



## Dimensional drawing

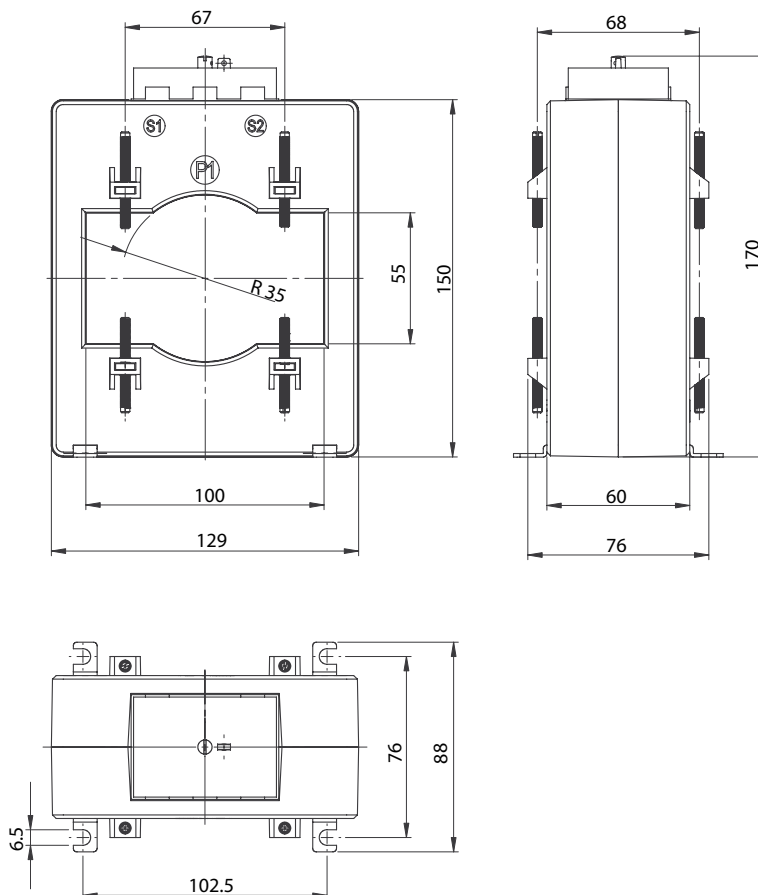



Type	Class	I <sub>pn</sub> [A]	I <sub>sn</sub> [A]	Security factor FS								Rated operation current		Maximum permissible voltage U <sub>m</sub> [kV]	Rated test voltage U <sub>p</sub> [kV]	Weight (approx.) [kg]	
				Burden								short-time thermal I <sub>th</sub> [A]	peak I <sub>dyn</sub> [A]				
				2.5 [VA]	5 [VA]	7.5 [VA]	10 [VA]	15 [VA]	20 [VA]	30 [VA]	45 [VA]						
ISWf	0.5S	600	5	10								60xI <sub>pn</sub>	150xI <sub>pn</sub>	0.72	3	2	
		750		10													
		800		10	10	5; 10											
		1000		10	10	5; 10											
		1200		10	10	5; 10	5; 10										
		1500		10	10	10	5; 10	5; 10									
		1600		10	10	10	5; 10	5; 10									
		2000		10	10	10	5; 10	5; 10	5; 10	5; 10							
		2500		10	10	10	10	5; 10	5; 10	5; 10	5; 10						
	0.2	1200	5 or 1	10	10	10						60xI <sub>pn</sub>	150xI <sub>pn</sub>				
		1500		10	10	10	5; 10	5; 10									
		1600		10	10	10	5; 10	5; 10									
		2000		10	10	10	5; 10	5; 10	5; 10								
		2500		10	10	10	10	5; 10	5; 10	5; 10							
	0.5	500	5 or 1	10	10	5; 10						60xI <sub>pn</sub>	150xI <sub>pn</sub>				
		600		10	10	5; 10	5; 10	5; 10									
		750		10	10	5; 10	5; 10	5; 10									
		800		10	10	5; 10	5; 10	5; 10									
		1000		10	10	5; 10	5; 10	5; 10									
		1200		10	10	5; 10	5; 10	5; 10	5; 10								
		1500		10	10	10	5; 10	5; 10	5; 10	5; 10							
		1600		10	10	10	5; 10	5; 10	5; 10	5; 10							
		2000		10	10	10	5; 10	5; 10	5; 10	5; 10	5; 10						
		2500		10	10	10	10	5; 10	5; 10	5; 10	5; 10						
	1; 3	500	5 or 1	10	10	5; 10	5; 10					60xI <sub>pn</sub>	150xI <sub>pn</sub>				
		600		10	10	5; 10	5; 10	5; 10									
		750		10	10	5; 10	5; 10	5; 10									
		800		10	10	5; 10	5; 10	5; 10									
		1000		10	10	5; 10	5; 10	5; 10	5; 10								
		1200		10	10	5; 10	5; 10	5; 10	5; 10								
1500		10		10	10	5; 10	5; 10	5; 10	5; 10								
1600		10		10	10	5; 10	5; 10	5; 10	5; 10								
2000		10		10	10	5; 10	5; 10	5; 10	5; 10	5; 10							
2500		10		10	10	10	5; 10	5; 10	5; 10	5; 10							

It is possible to order transformers of other parameters after prior arrangement with the manufacturer.  
There is a possibility of performing by special order transformers of primary current I<sub>pn</sub> up to 3000 A.

# Transformers type ISWg

Current transformers designed for mounting on current busbars of maximum dimensions 60 x 30 mm and a cable of maximum 46 mm diameter.

Primary current range from 300 A to 1500 A.



## Dimensional drawing

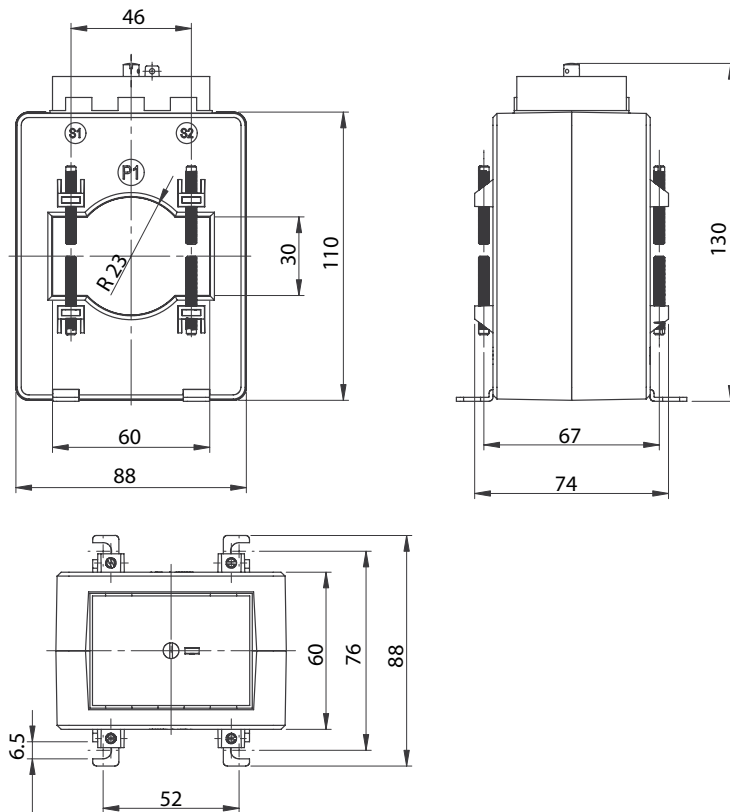

Type	Class	I <sub>pn</sub> [A]	I <sub>sn</sub> [A]	Security factor FS							Rated operation current		Maximum permissible voltage U <sub>m</sub> [kV]	Rated test voltage U <sub>p</sub> [kV]	Weight (approx.) [kg]
				Burden							short-time thermal I <sub>th</sub> [A]	peak I <sub>dyn</sub> [A]			
				2.5 [VA]	5 [VA]	7.5 [VA]	10 [VA]	15 [VA]	20 [VA]	30 [VA]					
ISWg	0.2S	1500	5	10	10	10	5; 10								
	0.5S	500		5; 10											
		600		10											
		750		10	5; 10	5; 10	5; 10								
		800	5	10	5; 10	5; 10	5; 10								
		1000		10	10	5; 10	5; 10	5; 10	5; 10	5; 10					
		1200		10	10	5; 10	5; 10	5; 10	5; 10	5; 10	5; 10				
		1500		10	10	10	5; 10	5; 10	5; 10	5; 10	5; 10				
	0.2	750		5	10	5; 10									
		800		5 or 1	10	5; 10									
		1000		10	10	5; 10	5; 10	5; 10							
		1200		10	10	5; 10	5; 10	5; 10							
		1500		5	10	10	5; 10	5; 10	5; 10	5; 10					
	0.5	300		5	10	10									
		400			5; 10										
		500			5; 10	5; 10	5; 10								
		600		5	10	5; 10	5; 10								
		750		5 or 1	10	5; 10	5; 10	5; 10							
		800		10	5; 10	5; 10	5; 10								
		1000			10	10	5; 10	5; 10	5; 10	5; 10	5; 10				
		1200			10	10	5; 10	5; 10	5; 10	5; 10	5; 10				
		1500		5	10	10	10	5; 10	5; 10	5; 10	5; 10				
		1; 3	300		5	10	10								
	400				5; 10	5; 10									
	500				5; 10	5; 10	5; 10								
	600			5	10	5; 10	5; 10	5; 10							
	750			5 or 1	10	5; 10	5; 10	5; 10							
	800			10	5; 10	5; 10	5; 10	5; 10							
1000				10	10	5; 10	5; 10	5; 10	5; 10	5; 10					
1200				10	10	5; 10	5; 10	5; 10	5; 10	5; 10					
1500			5	10	10	10	5; 10	5; 10	5; 10	5; 10					

It is possible to order transformers of other parameters after prior arrangement with the manufacturer.

# Transformers type ISWh1

Current transformers designed for mounting on current busbars of maximum dimensions 60 x 10 mm or 50 x 30 mm.  
Primary current range from 200 A to 1000 A.



## Dimensional drawing

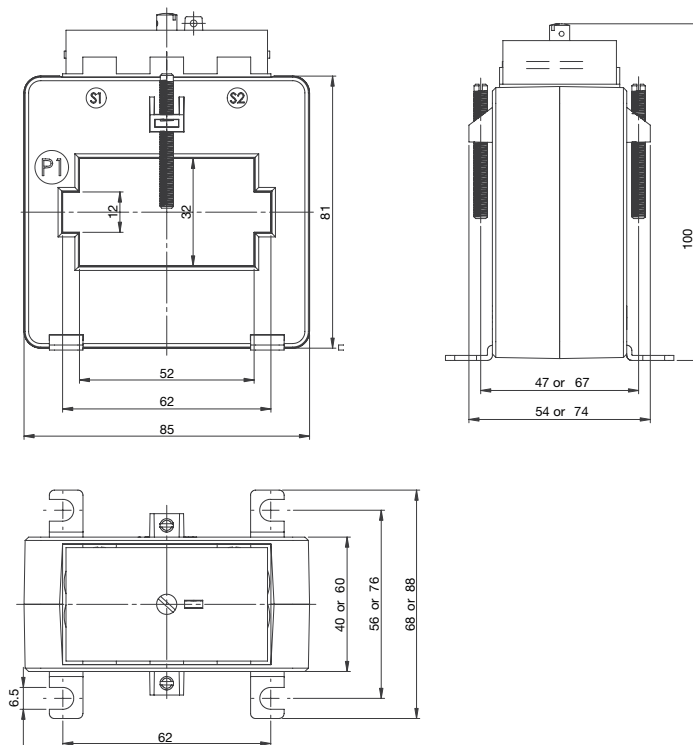

Type	Class	I <sub>pn</sub> [A]	I <sub>sn</sub> [A]	Security factor FS							Rated operation current		Maximum permissible voltage U <sub>m</sub> [kV]	Rated test voltage U <sub>p</sub> [kV]	Weight (approx.) [kg]				
				Burden							short-time thermal I <sub>th</sub> [A]	peak I <sub>dyn</sub> [A]							
				2.5 [VA]	5 [VA]	7.5 [VA]	10 [VA]	15 [VA]	20 [VA]	30 [VA]									
ISWh1	0.5S	300		10															
		400		10	5; 10														
		500		10	5; 10	5; 10													
		600	5	10	10	5; 10	5; 10												
		750		10	10	5; 10	5; 10	5; 10											
		800		10	10	5; 10	5; 10	5; 10											
		1000		10	5; 10	5; 10	5; 10	5; 10	5; 10	5; 10									
	0.2	500			10	5; 10													
		600	5		10	10													
		750	or		10	10													
		800	1		10	10													
		1000			10	5; 10	5; 10	5; 10	5; 10	5; 10									
	0.5	200			10														
		250			10	5; 10													
		300			10	5; 10	5; 10												
		400	5		10	5; 10	5; 10	5; 10	5; 10										
		500	or		10	5; 10	5; 10	5; 10	5; 10										
		600	1		10	10	5; 10	5; 10	5; 10	5; 10									
		750			10	10	5; 10	5; 10	5; 10	5; 10									
		800			10	10	5; 10	5; 10	5; 10	5; 10									
		1000			10	5; 10	5; 10	5; 10	5; 10	5; 10	5; 10								
		1; 3	200			10	5; 10												
	250				10	5; 10													
	300				10	5; 10	5; 10	5; 10											
	400		5		10	5; 10	5; 10	5; 10	5; 10										
	500		or		10	5; 10	5; 10	5; 10	5; 10	5; 10									
	600		1		10	10	5; 10	5; 10	5; 10	5; 10									
	750				10	10	5; 10	5; 10	5; 10	5; 10	5; 10								
800				10	10	5; 10	5; 10	5; 10	5; 10	5; 10									
1000				10	5; 10	5; 10	5; 10	5; 10	5; 10	5; 10	5; 10								

It is possible to order transformers of other parameters after prior arrangement with the manufacturer.

# Transformers type ISWh2

Current transformers designed for mounting on cable of maximum 46 mm diameter.  
Primary current range from 200 A to 1200 A.



## Dimensional drawing

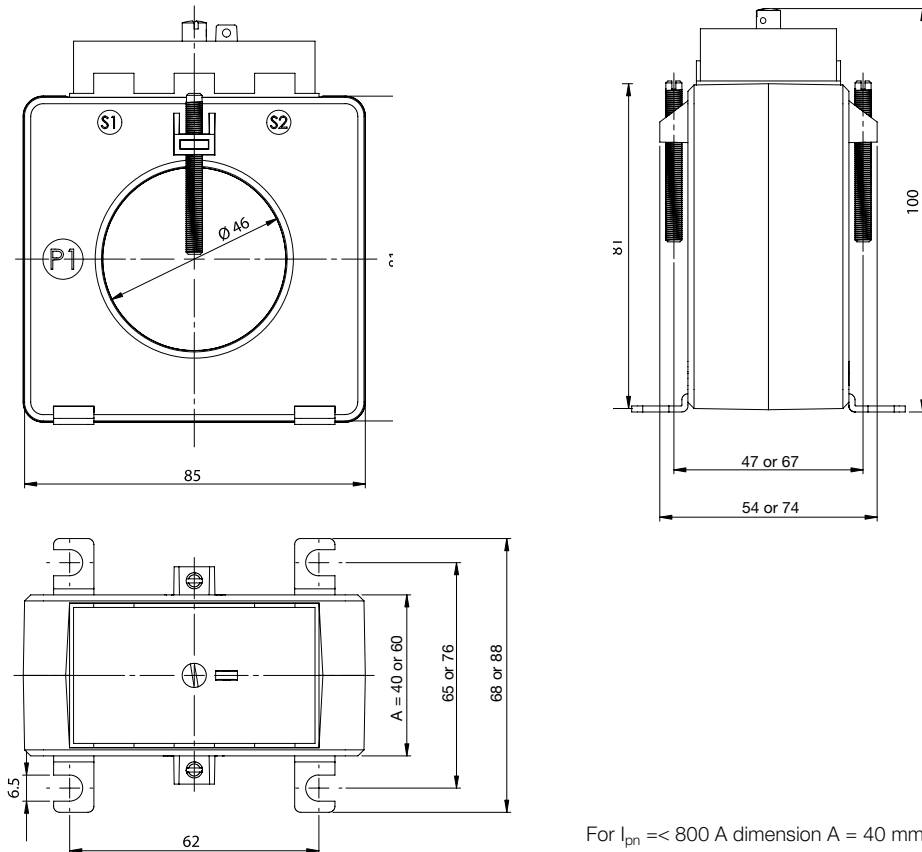

For  $I_{pn} \leq 800$  A dimension A = 40 mm  
For  $I_{pn} > 800$  A dimension A = 40 mm or 60 mm

Type	Class	I <sub>pn</sub> [A]	I <sub>sn</sub> [A]	Security factor FS						Rated operation current		Maximum permissible voltage U <sub>m</sub> [kV]	Rated test voltage U <sub>p</sub> [kV]	Weight (approx.) [kg]				
				Burden						short-time thermal I <sub>th</sub> [A]	peak I <sub>dyn</sub> [A]							
				2.5 [VA]	5 [VA]	7.5 [VA]	10 [VA]	15 [VA]	20 [VA]						30 [VA]			
ISWh2	0.5S	300	5	5; 10							60xI <sub>pn</sub>	150xI <sub>pn</sub>	0.72	3	0.8			
		400		5; 10	5; 10													
		500		5; 10	5; 10	5; 10												
		600		5; 10	5; 10	5; 10	5; 10											
		750		5; 10	5; 10	5; 10	5; 10	5; 10										
		800		5; 10	5; 10	5; 10	5; 10	5; 10	5; 10									
		1000		5; 10	5; 10	5; 10*	5; 10*	5; 10*	5; 10*									
		1200		5; 10	5; 10	5; 10*	5; 10*	5; 10*	5; 10*									
	0.2	500	5 or 1	5; 10	5; 10													
		600		5; 10	5; 10													
		750		5; 10	5; 10													
		800		5; 10	5; 10													
		1000		5; 10	5; 10	5; 10*	5; 10*	5; 10*										
		1200		5; 10	5; 10	5; 10*	5; 10*	5; 10*										
	0.5	200	5 or 1	5; 10														
		250		5; 10	5; 10													
		300		5; 10	5; 10	5; 10												
		400		5; 10	5; 10	5; 10	5; 10											
		500		5; 10	5; 10	5; 10	5; 10											
		600		5; 10	5; 10	5; 10	5; 10	5; 10										
		750		5; 10	5; 10	5; 10	5; 10	5; 10										
		800		5; 10	5; 10	5; 10	5; 10	5; 10										
		1000		5; 10	5; 10	5; 10*	5; 10*	5; 10*	5; 10*									
		1200		5; 10	5; 10	5; 10*	5; 10*	5; 10*	5; 10*									
		1; 3		200	5 or 1	5; 10	5; 10											
				250		5; 10	5; 10											
	300		5; 10	5; 10		5; 10	5; 10											
	400		5; 10	5; 10		5; 10	5; 10											
	500		5; 10	5; 10		5; 10	5; 10	5; 10										
	600		5; 10	5; 10		5; 10	5; 10	5; 10										
750	5; 10		5; 10	5; 10		5; 10	5; 10	5; 10										
800	5; 10		5; 10	5; 10		5; 10	5; 10	5; 10										
1000	5; 10		5; 10	5; 10*		5; 10*	5; 10*	5; 10*	5; 10*									
1200	5; 10		5; 10	5; 10*		5; 10*	5; 10*	5; 10*	5; 10*									

It is possible to order transformers of other parameters after prior arrangement with the manufacturer.  
\*dimension A = 60

# Transformers type IMR0

Current transformers of small dimensions designed for mounting on a cable or busbar. Applied mainly for control measurements. Primary current range from 50 A to 200 A.



## Dimensional drawing

IMR0 – current transformers for a cable max 18 mm or a busbar max 20 x 5 mm.

Version with secondary terminals

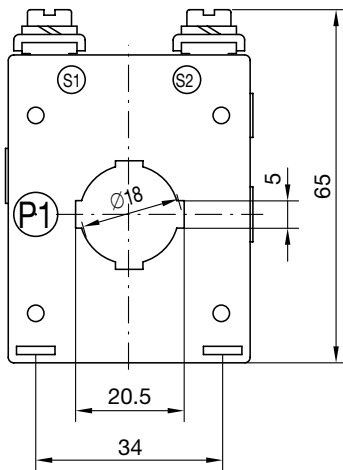

Version with leaded cables LYc length approximately 20 cm

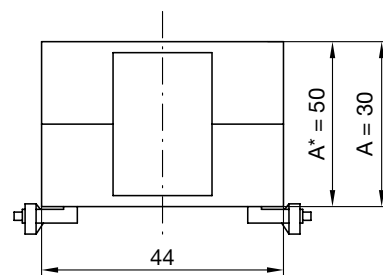
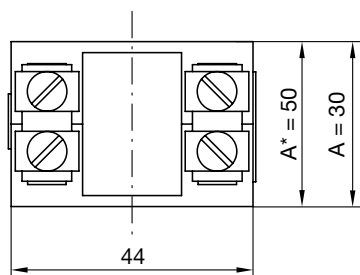
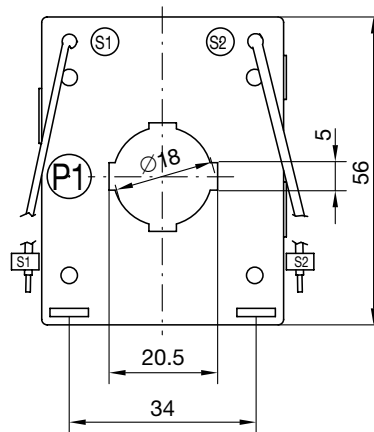



Type	Class	I <sub>pn</sub> [A]	I <sub>sn</sub> [A]	Security factor FS					Rated operation current		Maximum permissible voltage U <sub>m</sub> [kV]	Rated test voltage U <sub>p</sub> [kV]	Weight (approx.) [kg]
				Burden					short-time thermal I <sub>th</sub> [A]	peak I <sub>dyn</sub> [A]			
				1 [VA]	2.5 [VA]	4 [VA]	5 [VA]	7.5 [VA]					
IMRO	0.5	100	5	5; 10*					60xI <sub>pn</sub>	150xI <sub>pn</sub>	0.72	3	0.4
		150	or	5; 10	5; 10*								
		200	1		5; 10	5; 10*							
	1	50	1	5; 10									
		100		5; 10*	5; 10								
		150		5; 10	5; 10	5; 10*	5; 10*						
	3	200			5; 10	5; 10*	5; 10*	5; 10*					
		40		5; 10*									
		45	5	5; 10*									
		50	or	5; 10*									
		75	1	5; 10*	5; 10*								
		80			10								
		100		5; 10*	5; 10	5; 10*							
		150		5; 10	5; 10	5; 10*	5; 10*						
	5	200			5; 10	5; 10*	5; 10*	5; 10*					
		20		5; 10*									
		25		5; 10*									
		30	1	5; 10*									
		35		5; 10*									
		40		5; 10*									
		45		5; 10*									
		50	5	5; 10*									
		75	or	5; 10*	5; 10*								
		80	1		10								
		100		5; 10*	5; 10	5; 10*							
		150		5; 10	5; 10	5; 10*	5; 10*						
	200			5; 10	5; 10*	5; 10*	5; 10*						

It is possible to order transformers of other parameters after prior arrangement with the manufacturer.  
\*depth A=50 mm

# Transformers type IMR1a

Current transformers of small dimensions designed for mounting on a cable or busbar. Applied mainly for control measurements. Primary current range from 75 A to 400 A.



## Dimensional drawing

IMR1a – current transformers for a cable max 18 mm or a busbar max 20 x 10 mm.

### Version with secondary terminals

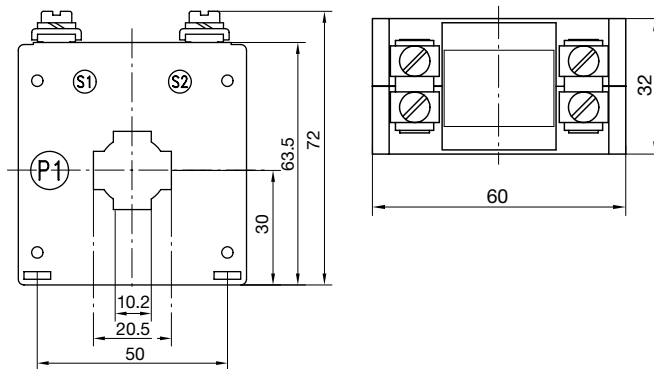

### Version with leaded cables LYc length approximately 20 cm

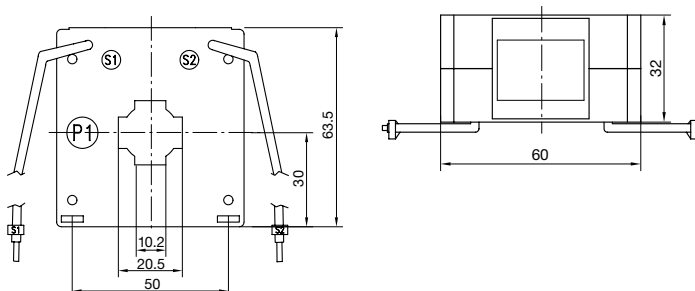

Type	Class	$I_{pn}$ [A]	$I_{sn}$ [A]	Security factor FS						Rated operation current		Maximum permissible voltage $U_m$ [kV]	Rated test voltage $U_p$ [kV]	Weight (approx.) [kg]						
				Burden						short-time thermal $I_{th}$ [A]	peak $I_{dyn}$ [A]									
				1 [VA]	2.5 [VA]	5 [VA]	7.5 [VA]	10 [VA]	15 [VA]											
IMR1a	0.5	150	5 or 1	10	5; 10					60xI <sub>pn</sub>	150xI <sub>pn</sub>	0.72	3	0.6						
		200		10	10; 5; 10															
		250			10; 5; 10															
		300			10; 5; 10; 5; 10															
		400			10; 10; 5; 10; 5; 10															
	1	75		5; 10																
		100		5; 10; 5; 10																
		150		10; 5; 10; 5; 10																
		200		10; 5; 10; 5; 10; 5; 10																
		250		10; 5; 10; 5; 10; 5; 10																
	3; 5	300		10; 5; 10; 5; 10; 5; 10																
		400		10; 10; 5; 10; 5; 10; 5; 10																
		50		5; 10																
		75		5; 10; 5; 10																
		100		5; 10; 5; 10																
		150		10; 5; 10; 5; 10																
		200		10; 5; 10; 5; 10; 5; 10																
		250		10; 5; 10; 5; 10; 5; 10																
	5	300		10; 5; 10; 5; 10; 5; 10; 5; 10																
		400		10; 10; 5; 10; 5; 10; 5; 10; 5; 10																
	5	40		5; 10																

It is possible to order transformers of other parameters after prior arrangement with the manufacturer.

# Transformers type IMR1b

Current transformers of small dimensions designed for mounting on a cable or busbar. Applied mainly for control measurements. Primary current range from 100 A to 500 A.



## Dimensional drawing

IMR1b – current transformers for a cable max 23 mm or a busbar max 25 x 10 mm.

### Version with secondary terminals

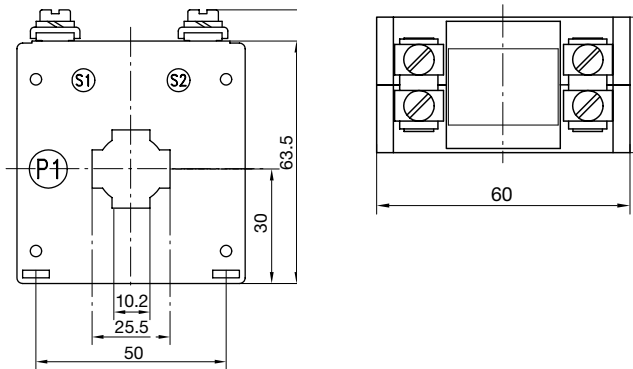

### Version with leaded cables LYc length approximately 20 cm

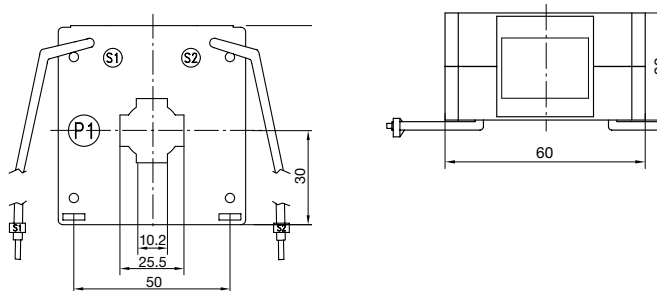

Type	Class	I <sub>pn</sub> [A]	I <sub>sn</sub> [A]	Security factor FS							Rated operation current		Maximum permissible voltage U <sub>m</sub> [kV]	Rated test voltage U <sub>p</sub> [kV]	Weight (approx.) [kg]				
				Burden							short-time thermal I <sub>th</sub> [A]	peak I <sub>dyn</sub> [A]							
				1 [VA]	1.5 [VA]	2.5 [VA]	5 [VA]	7.5 [VA]	10 [VA]	15 [VA]									
IMR1b	0.5	100		5; 10															
		150		5; 10	5; 10														
		200				5; 10													
		250				5; 10													
		300				5; 10	5; 10												
		400				10	5; 10	5; 10											
		500				10	10	5; 10	5; 10										
	1	100		5; 10															
		150		5; 10	5; 10	5; 10													
		200				5; 10	5; 10												
		250				5; 10	5; 10												
		300				5; 10	5; 10	5; 10											
		400				10	5; 10	5; 10	5; 10	5; 10	5; 10								
		500				10	5; 10	5; 10	5; 10	5; 10	5; 10								
	3	75	5	5; 10															
		100	or	5; 10	5; 10	5; 10						60xI <sub>pn</sub>	150xI <sub>pn</sub>	0.72	3	0.4			
		150	1	5; 10	5; 10	5; 10													
		200				5; 10	5; 10												
		250				5; 10	5; 10												
		300				5; 10	5; 10	5; 10											
		400				10	5; 10	5; 10	5; 10	5; 10	5; 10								
	5	50		5; 10															
		75		5; 10															
		100		5; 10	5; 10	5; 10													
		150		5; 10	5; 10	5; 10													
		200				5; 10	5; 10												
		250				5; 10	5; 10												
		300				5; 10	5; 10	5; 10											
400				10	5; 10	5; 10	5; 10	5; 10	5; 10										
500				10	5; 10	5; 10	5; 10	5; 10	5; 10										

It is possible to order transformers of other parameters after prior arrangement with the manufacturer.

# Transformers type IMR2

Current transformers of small dimensions designed for mounting on a cable or busbar. Applied mainly for control measurements. Primary current range from 150 A to 800 A.



## Dimensional drawing

IMR2 – current transformers for a cable max 30 mm or a busbar max 40 x 10 mm.

Version with secondary terminals

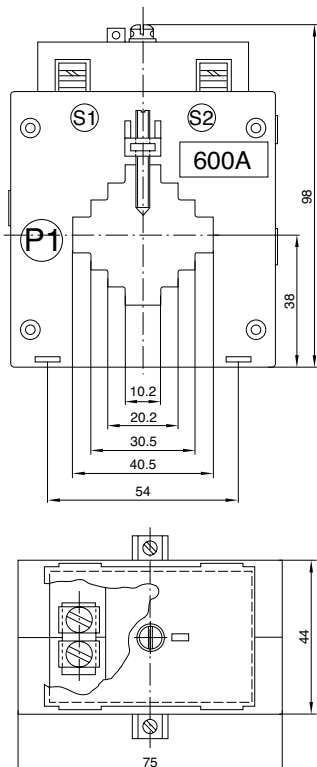

Version with leaded cables LYc length approximately 20 cm

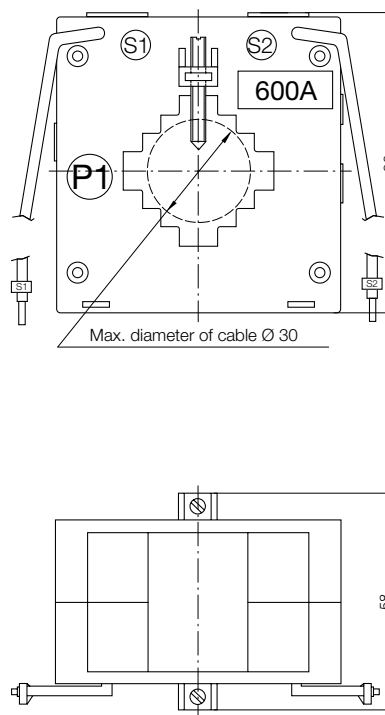

Type	Class	$I_{pn}$ [A]	$I_{sn}$ [A]	Security factor FS						Rated operation current		Maximum permissible voltage $U_m$ [kV]	Rated test voltage $U_p$ [kV]	Weight (approx.) [kg]	
				Burden						short-time thermal $I_{th}$ [A]	peak $I_{dyn}$ [A]				
				2.5 [VA]	5 [VA]	7.5 [VA]	10 [VA]	15 [VA]	20 [VA]						
IMR2	0.5S	400			10										
		500	5	5; 10	5; 10										
		600		10	10										
	0.2	400			10	5; 10									
		500	5			10	5; 10	5; 10							
		600					10	5; 10	5; 10						
	0.5	250			10	5; 10									
		300			10	5; 10	5; 10	5; 10							
		400	5		10	5; 10	5; 10	5; 10	5; 10						
		500	or	5; 10	5; 10	5; 10	5; 10	5; 10	5; 10						
		600	1	10	5; 10	5; 10	5; 10	5; 10	5; 10						
		630				5; 10	5; 10	5; 10	5; 10	5; 10	60xI <sub>pn</sub>	150xI <sub>pn</sub>	0.72	3	0.6
		650				5; 10	5; 10	5; 10	5; 10	5; 10					
	1; 3	800	5			5; 10	5; 10	5; 10	5; 10	5; 10					
		150			10										
		200			10	5; 10									
		250			10	5; 10	5; 10	5; 10							
		300	5		10	5; 10	5; 10	5; 10							
		400	or	10	5; 10	5; 10	5; 10	5; 10	5; 10						
		500	1	5; 10	5; 10	5; 10	5; 10	5; 10	5; 10	5; 10					
		600		10	5; 10	5; 10	5; 10	5; 10	5; 10	5; 10					
		630				5; 10	5; 10	5; 10	5; 10	5; 10					
		650				5; 10	5; 10	5; 10	5; 10	5; 10					
	800	5			5; 10	5; 10	5; 10	5; 10	5; 10						

It is possible to order transformers of other parameters after prior arrangement with the manufacturer.

# Transformers type INSOA

Current transformers for special applications. Their special advantage is fast saturation – FS2. Designed for mounting on leads of maximum 30 mm diameter. The transformer is equipped with holders allowing assembly of the transformer on current busbars of maximum dimensions 30 × 10 mm.

Primary current range from 100 A to 400 A.



## Dimensional drawing

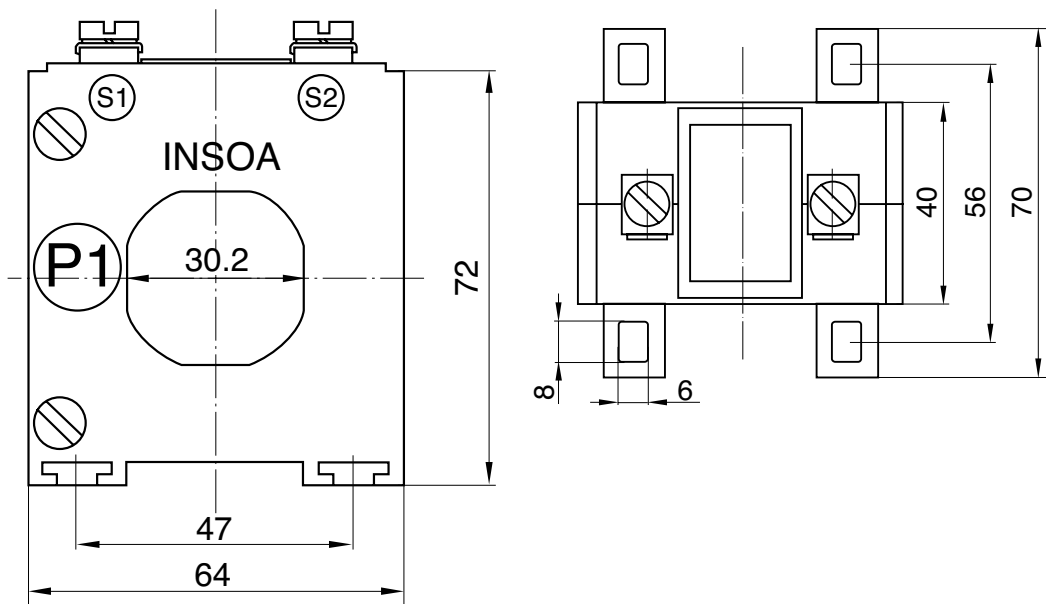



Type	Class	$I_{pn}$ [A]	$I_{sn}$ [A]	Security factor FS					Rated operation current		Maximum permissible voltage $U_m$ [kV]	Rated test voltage $U_p$ [kV]	Weight (approx.) [kg]
				Burden					short-time thermal $I_{th}$ [A]	peak $I_{dyn}$ [A]			
				2.5 [VA]	4 [VA]	5 [VA]	7.5 [VA]	10 [VA]					
INSOA	3; 5	100	5 or 1		2				$60 \times I_{pn}$	$150 \times I_{pn}$	0.72	3	0.4
		150			5; 10	2	2						
		200				2	2	2					
		250				2	2	2					
		300				2	2	2					
		400		10	5; 10	2	2	2					

It is possible to order transformers of other parameters after prior arrangement with the manufacturer.

# Accessories

## Voltage terminal

Transformers (excluding IMSd) can be equipped with a voltage terminal. It is an element not connected inside the transformer. It is used to connect the voltage circuit from the busbar to the terminal and then to the measurement system.

In transformers equipped with a cover there is the option of sealing this connection under the cover together with current circuit connections.

The voltage terminal comes as part of a set with the busbar, to which it is connected by a permanently mounted lead.



## Support for mounting the transformer on a TS35 mounting busbar

The mounting support allows mounting of some types of transformers on the TS35 mounting busbar (details in the transformer selection, table on page 52).

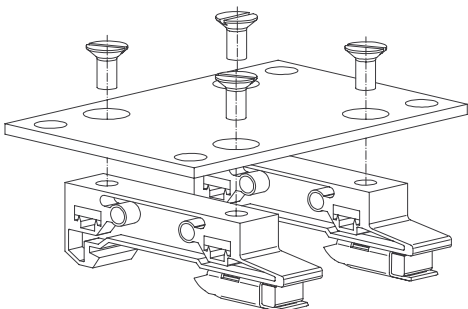

Sketch drawing of the mounting base

## Busbar mounting assembly

Bolt with openings for sealing, with a holder for 30 mm or 60 mm busbars.

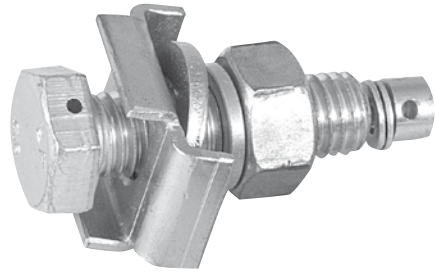

## Standard bolt with holder for 30 mm or 60 mm busbar

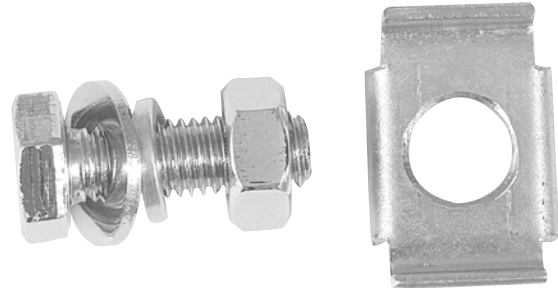

## Copper sleeve

Sleeve dimension  $\varnothing 20/\varnothing 13$  length 46 mm. Other dimensions available to special order.



## Busbars

Copper nickel plated busbars with a set of assembly bolts.



## Standard busbars

Busbar dimension [mm]	Number of bolts	Bolt dimension
20x5x150	2	M10
20x10x150	2	M10
30x5x150	2	M12
30x10x150	2	M12
40x5x150	2	M12
40x10x150	2	M12
60x5x150	2	M12
60x10x150	2	M12
80x8x230	4	M12
80x10x230	4	M12

It is possible to order busbars of other dimensions after prior arrangement with the manufacturer.

# Transformer selection table

Type	IMSa					IMSB					IMSc					IMSD					
Class	0.2S	0.5S	0.2	0.5	1; 3	0.2S	0.5S	0.2	0.5	1; 3	0.2S	0.5S	0.2	0.5	1; 3	0.2S	0.5S	0.2	0.5	1; 3	
Primary current	1																				
	2																				
	3																				
	5																				
	10																				
	15																				
	20																				
	25																				
	30																				
	40																				
	50																				
	60																				
	75																				
	100					1															
	125																				
	150				2.5	5															
	200				5	7.5															
	250		5	2.5	5	10															
	300		5	5	10	15															
	400		7.5	7.5	15	15			5	10	10		2.5	2.5	10	10					
	500	5	7.5	10	15	20		5	5	10	15				10	20				5	5
	600	5	15	5	15	20	5	10	10	15	20			5	10	20				10	10
	750							5	10	20	20			5	15	20				10	10
	800						5	5	10	20	20		5	7.5	15	20				10	10
	1000						7.5	15	10	20	20	5	10	20	30	30		10	10	15	15
1200											5	10	20	30	30			10	15	15	
1500											5	15	15	20	20			10	20	30	
1600													15	20	20		10	10	30	30	
2000											7.5	10	15	20	20		30	15	60	60	
2500											10	10	20	20	20	7.5	30	30	60	60	
3000																30	30	45	60	60	
4000																	60	60	90	90	
5000																	60	60	90	120	
dimensions [mm]	width				60					80					100					184	
	depth					50				44					52					46	
	height					84				98					127					194	
window [mm]	busbar				40x10					60x10					80x10				120x30; 100x50		
	cable Ø				-					-					-					86	
primary current [A]				150-600					400-1000					400-2500					500-5000		
mounting	slides				●				●					●					●		
	assembly support				●				●					●					●		
	on a current circuit				U				U					Sd					Sd		
insulation class*				A					A					E					E		

S – standard; ● – available as additional equipment; ● – not available; U – holder; Sd – set bolts

Provided data refer to the secondary current value of 5A and FS10.

Transformer maximum loading values in [VA] have been given in the table, at a given value of the primary current in [A] in a given class.

More details and possibility of FS5 design have been given inside the catalogue.

\*Insulation class B available by special order.

After arrangement with the manufacturer there is a possibility of transformer design of other: accuracy class, ratio, power or with an extended current range (ext. 150%; 200%).



# Transformer selection table

Type	ISWf				ISWg				ISWh1				ISWh2				IMPa						
Class	0.5S	0.2	0.5	1; 3	0.2S	0.5S	0.2	0.5	1; 3	0.5S	0.2	0.5	1; 3	0.5S	0.2	0.5	1; 3	0.5S	0.2	0.5	1; 3		
Primary current	1																						
	2																						
	3																						
	5																						
	10																						
	15																						
	20																						
	25																						
	30																						
	40																						
	50																						
	60																						
	75																						
	100																				2.5	5	
	125																				5	5	
	150																				7.5	10	
	200											2.5	5			2.5	5	10	5	15	15		
	250											5	5			5	5	10	7.5	15	20		
	300								5	5	2.5	7.5	10		2.5	7.5	10	10	7.5	20	20		
	400								2.5	5	5	10	10		5	10	10						
	500			10	15		2.5	7.5	7.5		7.5	5	10	15	7.5	5	10	15					
	600			15	15		2.5	7.5	10		10	5	15	15	10	5	15	15					
	750	2.5		15	15		10	5	10	10	15	5	15	20	15	5	15	20					
	800	7.5		15	15		10	5	10	15	15	5	15	20	15	5	15	20					
	1000	7.5		15	20		20	15	30	30	20	15	20	30	20	15	20	30					
1200	10		20	20		30	15	30	30					20	15	20	30						
1500	15	15	30	30	10	30	20	30	30														
1600	15	15	30	30																			
2000	30	20	45	45																			
2500	30	20	30	30																			
3000																							
4000																							
5000																							
dimensions [mm]	width			129				88				85			85					74			
	depth			60				60			40; 60			40; 60						45			
	height			170				130				100			100					95			
window [mm]	busbar		100x55					60x30			60x10; 50x30									20x10			
	cable Ø		70					46							45					20			
primary current [A]			500-2500					300-1500					200-1000				200-1200				100-300		
mounting	slides			S				S				S			S					S			
	assembly support			●				●				●			●					●			
	on a current circuit			Sd				Sd				Sd			Sd					U			
insulation class*			E				E				E			E					A				

S – standard; ● – available as additional equipment; ● – not available; U –holder; Sd – set bolts

Provided data refer to the secondary current value of 5A and FS10.

Transformer maximum loading values in [VA] have been given in the table, at a given value of the primary current in [A] in a given class.

More details and possibility of FS5 design have been given inside the catalogue.

\*Insulation class B available by special order.

After arrangement with the manufacturer there is a possibility of transformer design of other: accuracy class, ratio, power or with an extended current range (ext. 150%; 200%).



# Primary current range

Type	50 A	75 A	100 A	150 A	200 A	250 A	300 A	400 A	500 A	600 A	800 A	1000 A	1200 A	1500 A	1600 A	2500 A	4000 A	5000 A	
IMR0	•	•	•	•	•														
IMW	•	•	•	•	•	•	•												
ISWc	•	•	•	•	•	•	•	•	•										
IMR1a		•	•	•	•	•	•	•											
IMPa			•	•	•	•	•												
INSOA			•	•	•	•	•	•											
IMR1b			•	•	•	•	•	•	•										
IMPb			•	•	•	•	•	•	•	•									
IMSa				•	•	•	•	•	•	•	•								
IMR2				•	•	•	•	•	•	•	•								
ISWh1					•	•	•	•	•	•	•	•							
ISWh2					•	•	•	•	•	•	•	•	•						
SWd1						•	•	•	•	•	•	•	•						
ISWb						•	•	•	•	•	•	•	•	•					
ISWg							•	•	•	•	•	•	•	•					
IMsb								•	•	•	•	•	•	•					
IMSc									•	•	•	•	•	•					
ISWe									•	•	•	•	•	•					
ISWb2									•	•	•	•	•	•					
ISWf									•	•	•	•	•	•					
IMsd									•	•	•	•	•	•					
ISWd2										•	•	•	•	•					

# Certificates







# Contact us

## **ABB Sp. z o.o.**

### **Branch in Przasnysz**

59 Leszno Str.

06-300 Przasnysz, Poland

Phone: +48 29 75 33 377, +48 29 75 33 233

Fax: +48 29 75 33 327

**[www.abb.pl](http://www.abb.pl)**

We reserve the right to make technical changes or modify the contents of this document without prior notice. With regard to purchase orders, the agreed particulars shall prevail.

ABB does not accept any responsibility whatsoever for potential errors or possible lack of information in this document.

We reserve all rights in this document and in the subject matter and illustrations contained therein.

Any reproduction – in whole or in parts – is forbidden without ABB's prior written consent.

© Copyright 2011 ABB

All rights reserved